



Enriching Lives

**ILLUSTRATED SPARE PART LIST
FOR**

**6R1080T ENGINE
S/F POWER GENERATION
A/C – INTERNACO SPAIN**

**APPLICATION CODE NO.
6H.2465**

KIRLOSKAR OIL ENGINES LIMITED

Regd. Office: Laxmanrao Kirloskar Road, Khadki, Pune - 411 003, INDIA.
Tel.: +91 (20) 2581 0341, 2581 5341. Fax: +91 (20) 2581 3208, 2581 0209.
email: global@koel.co.in Website: www.kirloskar.com

AUGUST – 2006

PUBLICATION NO. 6H.041.98.0.00

GROUP INDEX
APPLICATION CODE 6H.2465

SR.NO.	GROUP NO.	DESCRIPTION	QTY.	PAGE NO.
1	6H.443	AIR CLEANER & MOUNTING (FOR CCV)	1	4, 5
2	6H.010...EXP	AIR INLET MANIFOLD	1	6
3	6H.058	AIR PIPE (6R1080 TC ENGINE)	1	7
4	04.367.1	ALTERNATOR (STAGE 1) MICO,12V55A	1	8
5	4H.198	ALTERNATOR MOUNTING AND BELT GUARD (TURBO)WITH 68PCD PULLEY SINGLE GROOVE	1	9, 10
6	6H.003	CAM SHAFT	1	11
7	6H.018	CARNKSHAFT PULLEY (1GR,172 PCD, A SEC) WITH EXTN PULLEY(2 GR.,140 PCD, B SEC)	1	12
8	6H.441	CCV ARRANGEMENT FOR INTERNACO ENGINE	1	13
9	6H.021...EXP	CENTRIFUGAL LUB OIL FILTER	1	14
10	4H.013...EXP	COVER FOR FUEL PUMP GEAR (AUTO TIMER)	1	15
11	6H.002	CRANK SHAFT	1	16
12	6H.007	CYLINDER HEAD	1	17 TO 19
13	2H.008	CYLINDER LINER.(105 DIA)	6	20
14	2H.013...EXP	DELIVERY BODY	1	21
15	06.248	DIP STICK (20DEG INCL SHORT)	1	22
16	6H.033	ENGINE MOUNTING FOOT	2	23
17	6H.011	EXHAUST MANIFOLD	1	24
18	F6.503	EXHAUST SILENCER AND MTG	1	25
19	F6.550	EXPANSION BELLOW (4") AND MOUNTING	1	26
20	6H.031	FAN DRIVE ARRANGEMENT	1	27, 28
21	6H.104	FASTENER FOR WATER PUMP PULLEY MOUNTING (FOR 6R1080 AND HE FF APPLICATION)	1	29
22	6H.257	FLYWHEEL (HEAVY)	1	30
23	4H.038	FLYWHEEL HOUSING(SAE3-144.5)	1	31
24	4H.179...EXP	FRONT COVER FOR PG APPLICATION	1	32
25	2H.011	FUEL PUMP GEAR.	1	33
26	6H.054...EXP	FUEL PUMP V.S. EXPORT	1	34, 35
27	6H.437	GAS OUTLET BEND	1	36
28	6H.020...EXP	GEAR CASING	1	37
29	6H.009	HIGH PRESSURE PIPE (700MM)	1	38
30	6H.026	HOUSING FOR EXHAUST OUTLET (K26 TURBO)	1	39
31	4H.154	INJECTOR & MTG. (TURBOCHARGED ENGINE)	6	40
32	4H.237	INTERMEDIATE GEAR AND SUPPORT (FOR ENGINE W/O AUTO TIMER)	1	41
33	6H.014...EXP	L.O.COOLER (EXPORT)	1	42, 43
34	6H.048	LIFTING HOOK	1	44
35	6H.047	LUB OIL PUMP	1	45 TO 47
36	6H.444	LUB OIL SUMP FOR CCV	1	48
37	2H.092.1	LUBE OIL PR GAUGE SENDOR	1	49

TITLE: -AIR CLEANER & MOUNTING (FOR CCV)

GROUP: - 6H.443

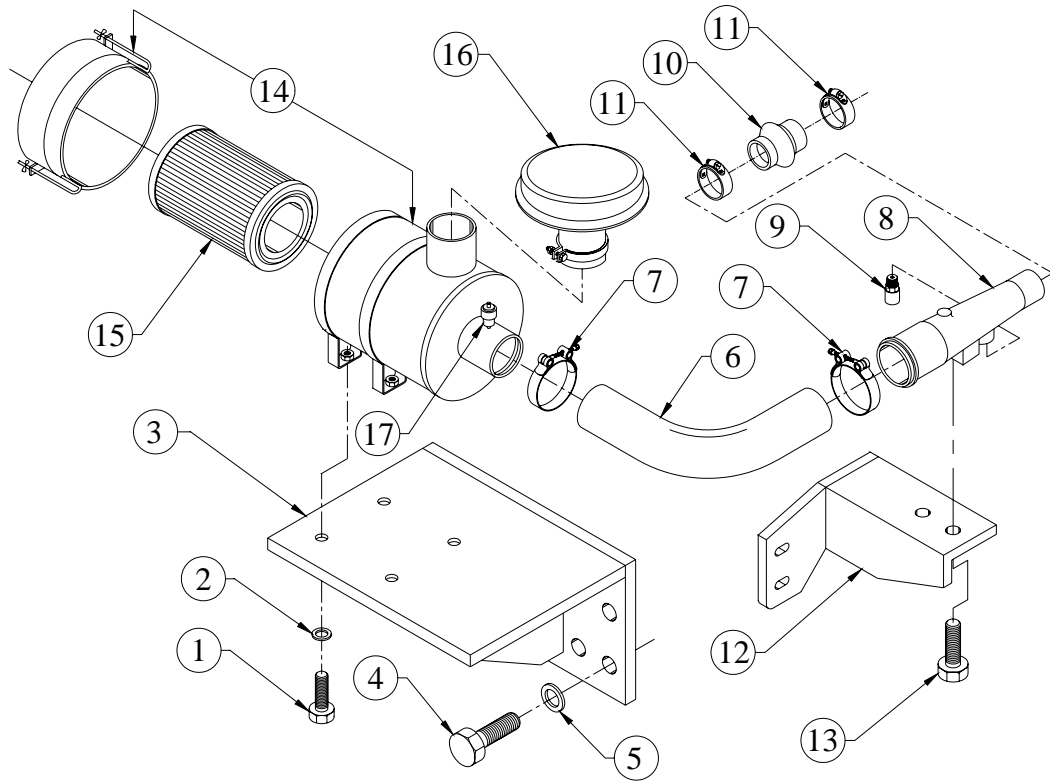

SR.NO.	PART NO.	DESCRIPTION	QTY.	REMARKS
1	50.003.08.025	SET SCREW - M8X1.25X25 - 8.8	4	
2	50.506.08.000.	PLAIN MACHINED WASHER - M8	6	
3	6H.028.01.0.00	BRACKET FOR AIR CLEANER	1	
4	50.003.10.030	SET SCREW - M10X1.5X30 - 8.8	6	
5	50.506.10.000	PLAIN MACHINED WASHER - M10	6	
6	F6.594.06.0.00	HOSE FOR AIR CLEANER	1	
7	06.376.04.0.00	T BOLT CLAMP KLIPCO TB108 / JUPITOR (108 TO 116 DIA)	2	
8	6H.443.01.0.PR	AIR INLET PIPE	1	
9	6H.443.02.0.PR	ADAPTOR FOR AIR INLET PIPE	1	
10	4H.168.03.0.00	RUBBER HOSE (COMPRESSOR OUTLET)-K24 TURBO	1	
11	30.650.04.0.00	HOSE CLIP (S.S.60 DIA.)	2	
12	6H.028.03.0.00	BRACKET FOR AIR PIPE	1	
13	50.003.08.016.	SET SCREW - M8X1.25X16 - 8.8	2	
14	F6.504.01.0.00	AIR CLEANER (14") WITH MTG STRAP, CAP (1 ELEMENT)	1	CONSISTING OF SR. NO.-15
15	F6.504.08.0.00	AIRCLEANER ELEMENT (14")	1	

TITLE :- AIR PIPE (6R1080 TC ENGINE)

GROUP :- 6H.058

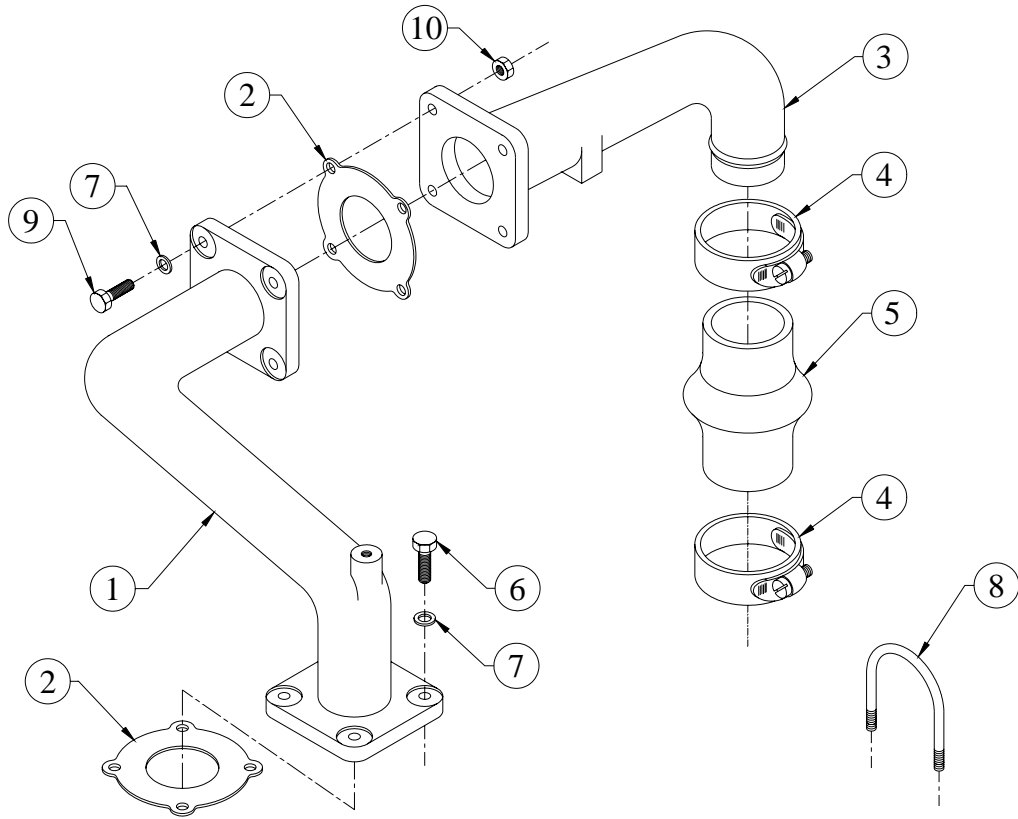

SR.NO.	PART NO.	DESCRIPTION	QTY.	REMARKS
1	6H.058.01.0.00	AIR PIPE (TURBOCHARGER TO INLET)	1	
2	6H.058.02.0.00	JOINT FOR AIR PIPE	1	
3	6H.030.08.0.00	AIR PIPE (TURBOCHARGER TO CAC) - T/C SIDE	1	
4	30.650.04.0.00	HOSE CLIP (S.S.60 DIA.)	2	
5	4H.168.03.0.00	RUBBER HOSE (COMPRESSOR OUTLET)-K24 TURBO	1	
6	50.003.08.016.	SET SCREW - M8X1.25X16 - 8.8	2	
7	50.506.08.000.	PLAIN MACHINED WASHER - M8	10	
8	6H.030.03.0.00	CLAMP FOR CAC PIPE	2	
9	50.003.08.030.	SET SCREW - M8X1.25X30 - 8.8	4	
10	50.006.08.000.	NUT- M8X1.25 - GR.8	4	

TITLE :- ALTERNATOR MOUNTING AND BLT GAURD (TURBO)

GROUP :- 4H.198

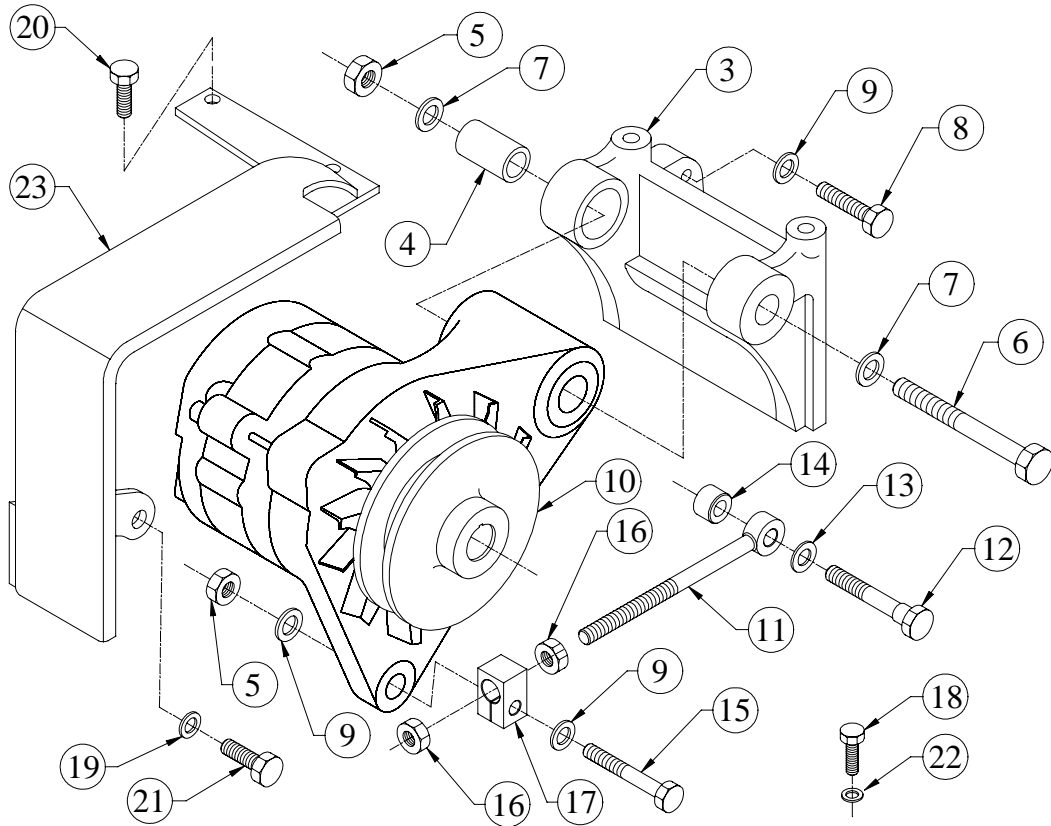

SR.NO.	PART NO.	DESCRIPTION	QTY.	REMARKS
*1	4H.198.10.0.00	ALTERNATOR MOUNTING KIT	1	CONSISTING OF SR. NO.- 2, 8 TO 19
*2	4H.044.20.0.00	MOUNTING SUBASLY. FOR ALTERNATOR	1	CONSISTING OF SR. NO.- 3 TO 7
3	48.175.07.0.00	BKT.FOR ALT	1	
4	48.067.04.0.00	BUSH FOR ALTERNATOR (IN BRACKET)	1	
5	50.006.10.000.	NUT - M10X1.5 - GR.8	1	
6	48.067.03.7.00	DOWEL BOLT FOR ALTERNATOR	1	
7	50.506.10.000.	PLAIN MACHINED WASHER - M10	2	
8	50.003.10.040.	SET SCREW - M10X1.5X40 - 8.8	2	
9	50.506.10.000.	PLAIN MACHINED WASHER - M10	6	
10	3H.041.02.0.00	PULLEY FOR ALTERNATOR (SPA 68 PCD)	1	
11	4H.329.24.0.00	EYE BOLT	1	
12	4H.198.02.0.00	LOCATING BOLT (FOR EYE BOLT)	1	
13	50.506.12.000.	PLAIN MACHINED WASHER - M12	1	

TITLE :- ALTERNATOR MOUNTING AND BLT GAURD (TURBO)

GROUP :- 4H.198

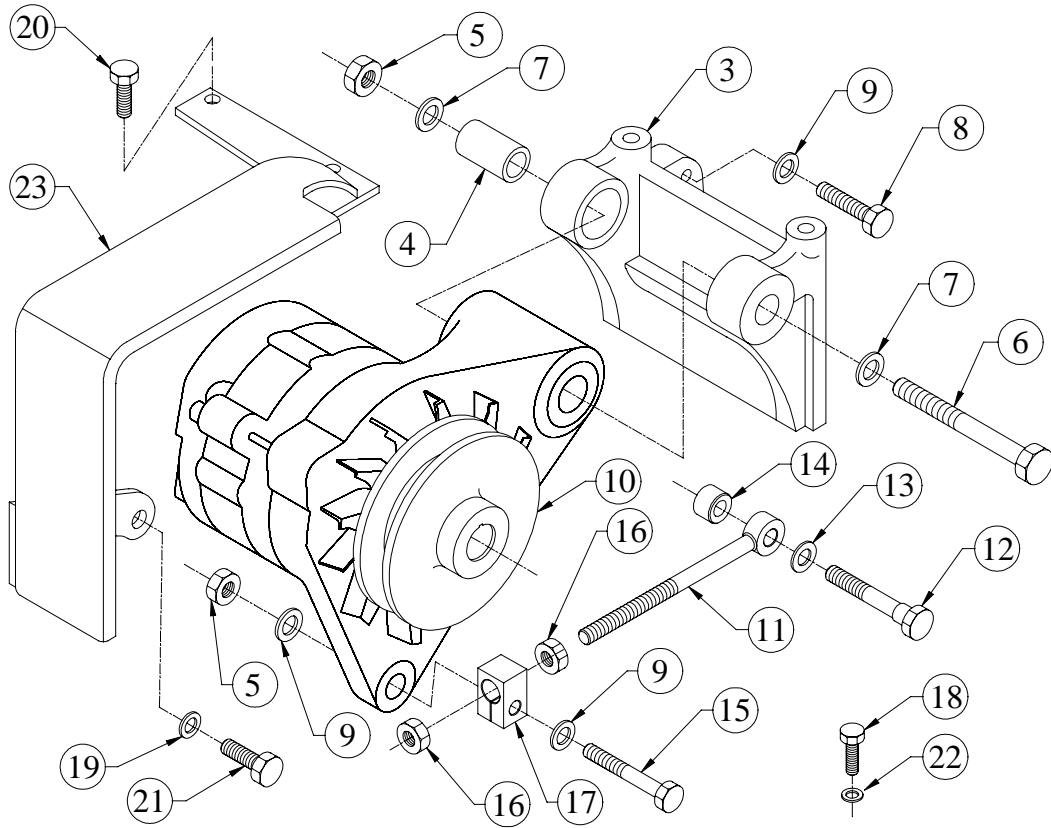

SR.NO.	PART NO.	DESCRIPTION	QTY.	REMARKS
14	4H.198.03.0.00	SPACER (FOR EYE BOLT)	1	
15	50.002.10.055	SET BOLT - M10X1.5X55 - 8.8	1	
16	50.006.10.000	NUT - M10X1.5 - GR.8	2	
17	4H.329.26.0.00	SWIVEL PIECE	1	
18	50.003.08.018	SET SCREW - M8X1.25X18 - 8.8	1	
19	50.506.08.000	PLAIN MACHINED WASHER - M8	1	
20	50.003.06.012	SET SCREW - M6X1X12 - 8.8	2	
21	50.003.08.020	SET SCREW - M8X1.25X20 - 8.8	1	
22	50.506.08.000	PLAIN MACHINED WASHER - M8	3	
23	4H.198.04.0.00	BELT GUARD	1	

TITLE :- CAM SHAFT

GROUP :- 6H.003

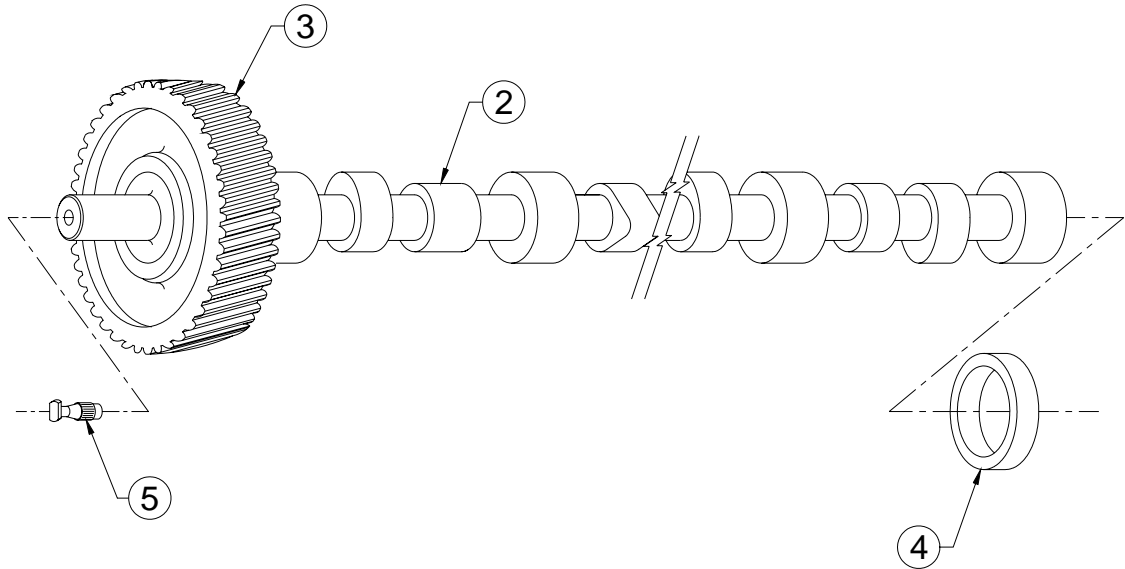

SR.NO.	PART NO.	DESCRIPTION	QTY.	REMARKS
*1	6H.003.10.0.00	CAMSHAFT AND GEAR ASSLY	1	CONSISTING OF SR. NO. – 02 TO 03
2	6H.003.01.0.00	CAMSHAFT	1	
3	03.006.04.0.00	CAM SHAFT GEAR	1	
4	4H.003.02.0.00	THRUST WASHER FOR CAM SHAFT	1	
5	03.117.02.0.00	PIN	1	

TITLE :- CRANKSHAFT PULLEY (SPB SECT)

GROUP :- 6H.018

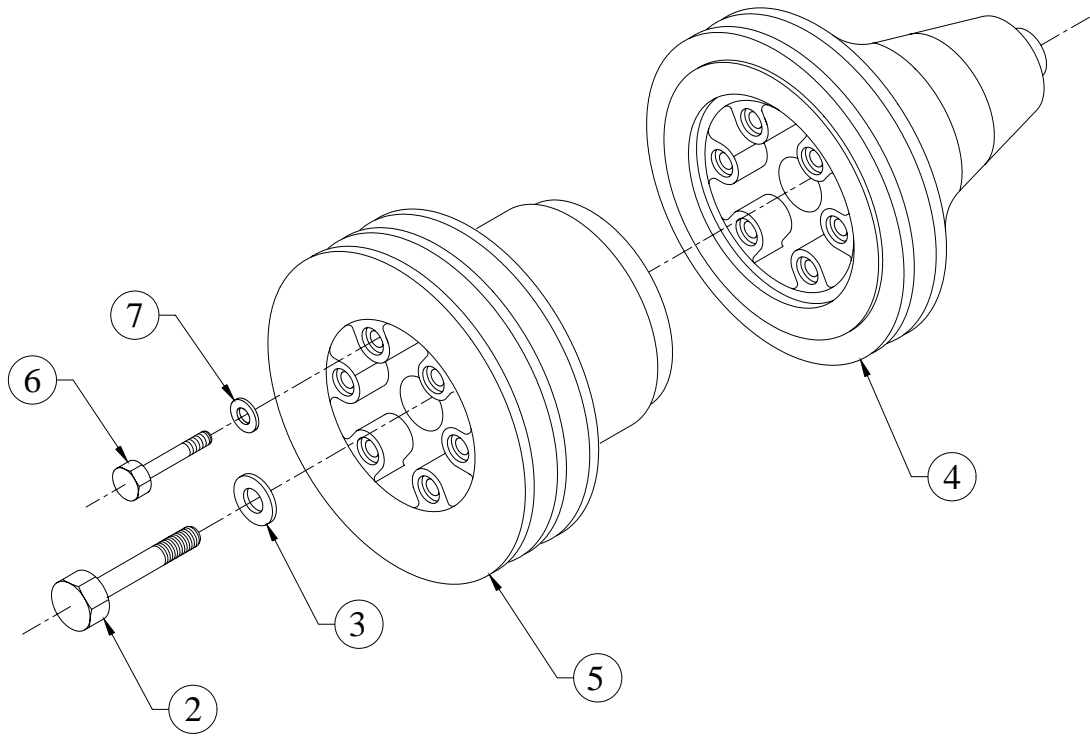

SR.NO.	PART NO.	DESCRIPTION	QTY.	REMARKS
*1	6H.018.10.0.00	SUB ASSLY.OF EXTN PULLEY+CRANK PULLEY	1	CONSISTING OF SR NO. 4 TO 7
2	03.016.02.0.00	CRANK PULLY BOLT-UPDATED	1	
3	03.016.03.0.00	WASHER (FOR CRANK PULLY BOLT)-UPDATED	1	
4	6H.018.02.0.00	CRANK SHAFT PULLEY (SPA SINGLESECTION, 172 PCD)	1	
5	6H.018.03.0.00	EXTENSION PULLEY (B SECTION, 140 PCD)	1	
6	50.002.08.040	SET BOLT M8x1.25x40-8.8	6	
7	34.017.05.0.00	WASHER FOR FUEL PUMP GEAR	6	

**TITLE: -CCV ARRANGEMENT FOR
INTERNACO ENGINE**

GROUP: - 6H.441

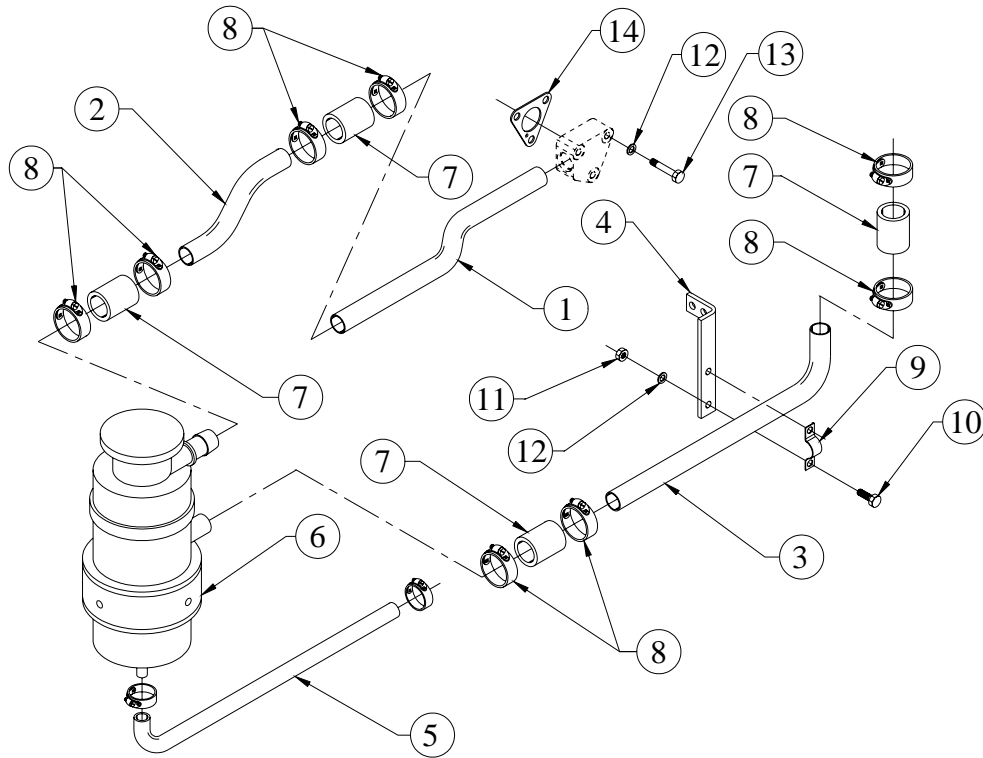

SR.NO.	PART NO.	DESCRIPTION	QTY.	REMARKS
1	6H.441.02.0.PR	ADAPTOR PIPE	1	
2	6H.441.03.0.PR	CCV VALVE INLET PIPE	1	
3	6H.441.04.0.PR	OUTLET PIPE (CCV VALVE)	1	
4	6H.441.05.0.PR	SUPPORT PLATE (CCV VALVE)	1	
5	6H.441.11.0.PR	DRAIN PIPE (FOR CCV VALVE)	1	
6	6H.441.12.0.00	CCV VALVE (DONALDSON -- PART NO. SPS040019)	1	
7	02.601.04.0.00	HOSE FOR INLET PIPE	4	
8	50.519.07.000.	WORM DRIVE HOSE CLIP (35 MM)	8	
9	02.601.08.0.00	CLAMP FOR BREATHER INLET PIPE	1	
10	50.003.08.020	SET SCREW – M8X1.25X20 - 8.8	2	
11	50.006.08.000	NUT- M8X1.25 - GR.8	2	
12	50.506.08.000	PLAIN MACHINED WASHER - M8	5	
13	50.002.08.045	SET BOLT - M8X1.25X45 - 8.8	3	
14	6H.024.02.0.00	JOINT (ADAPTOR FOR BREATHER)	1	

TITLE :- CENTRIFUGE LUB OIL FILTER

GROUP :- 6H.021...EXP

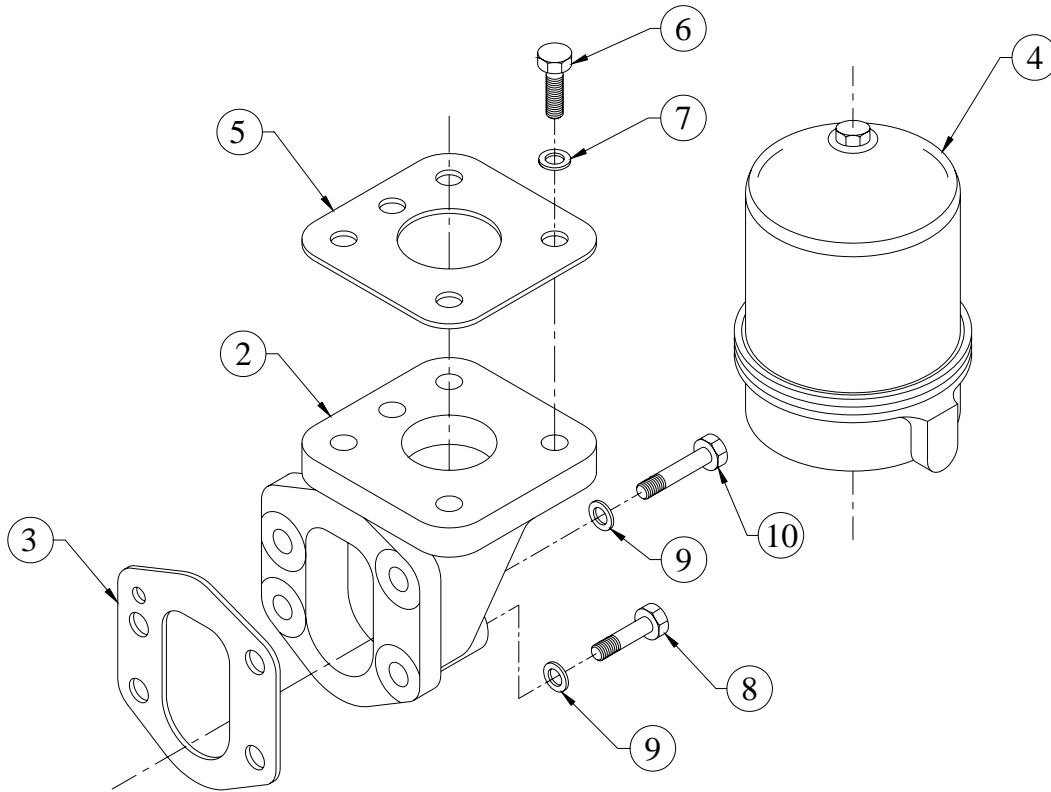

SR.NO.	PART NO.	DESCRIPTION	QTY.	REMARKS
*1	6H.021.20.0.00	CENTRIFUGE FILTER & HEADER ASSLY.	1	CONSISTING OF SR. NO. 2 TO 7
2	6H.021.01.0.00	ADAPTOR FOR CENTRIFUGAL LUB OIL FILTER	1	
3	6H.021.11.0.00	JOINT FOR CENTRIFUGAL FILTER ADAPTOR	1	
4	F6.024.46.0.00	CENTRIFUGAL FILTER (BHAGYASHREE 0.3)	1	
5	F6.024.75.0.00	JOINT FOR GLACIER FILTER	1	
6	50.003.08.025	SET SCREW – M8x1.25x25 – 8.8	4	
7	50.506.08.000.	PLAIN MACHINED WASHER - M8	4	
8	50.002.08.055	SET BOLT - M8X1.25X55 - 8.8	2	
9	50.506.08.000	PLAIN MACHINED WASHER - M8	4	
10	50.002.08.075	SET BOLT - M8X1.25X75 - 8.8	2	

**TITLE :- COVER FOR FUEL PUMP GEAR
(AUTO TIMER)**

GROUP :- 4H.013...EXP

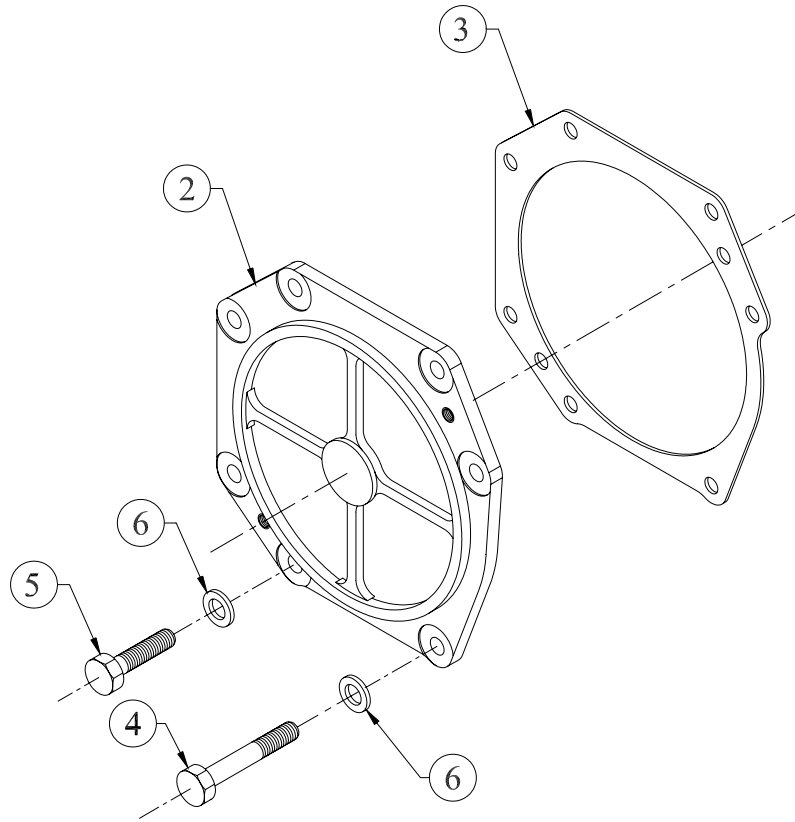

SR.NO.	PART NO.	DESCRIPTION	QTY.	REMARKS
*1	4H.266.10.0.00	COVER FOR FUEL PUMP GEAR WITH JOINT (USA)	1	CONSISTING OF SR. NO. 2 & 3
2	2H.017.03.0.00	COVER FOR FUEL PUMP GEAR	1	
3	2H.017.11.0.00	JOINT FOR COVER FOR FUEL PUMP GEAR	1	
4	50.002.08.045	SET BOLT - M8X1.25X45 - 8.8	5	
5	50.003.08.020	SET SCREW - M8X1.25X20 - 8.8	2	
6	50.506.08.000	PLAIN MACHINED WASHER - M8	7	

TITLE:- CRANK SHAFT

GROUP:- 6H.002

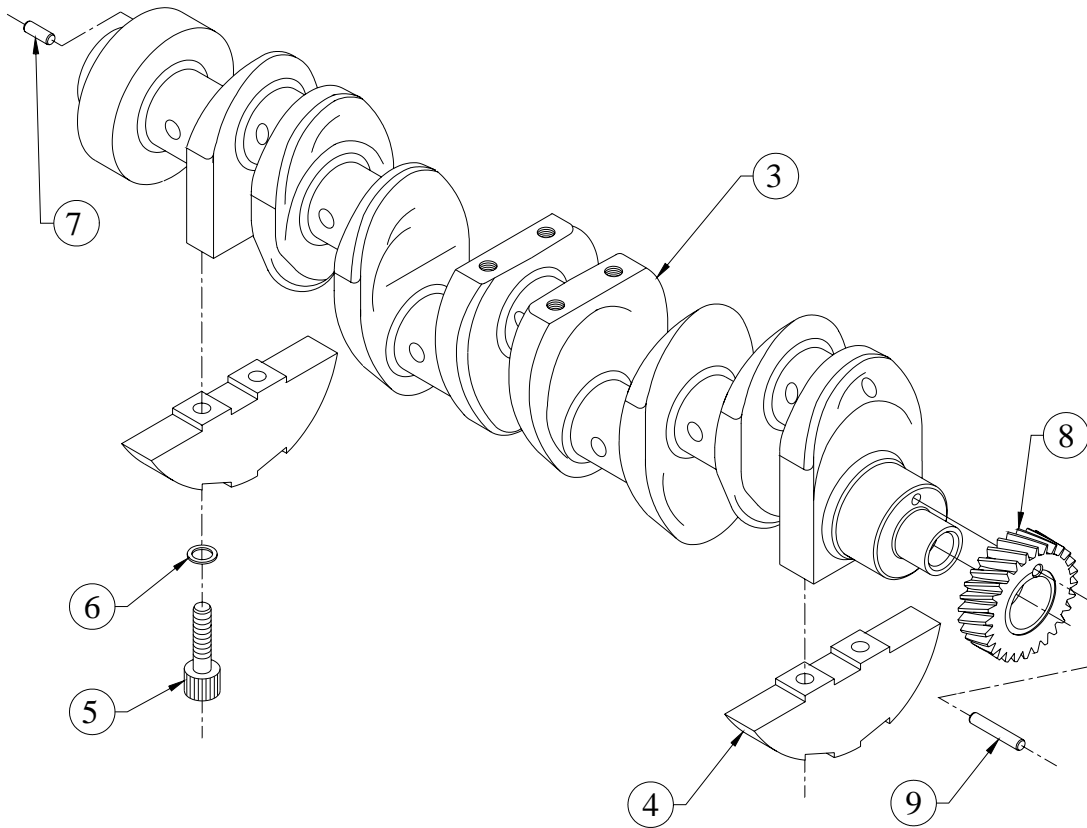

SR.NO.	PART NO.	DESCRIPTION	QTY.	REMARKS
*1	6H.002.20.0.00	CRANK SHAFT & CRANK GEAR ASSLY	1	CONSISTING OF SR. NO. 2, 8 & 9
*2	6H.002.10.0.00	CRANKSHAFT ASSLY	1	CONSISTING OF SR. NO. 3 TO 7
3	6H.002.02.0.00	CRANKSHAFT (SINGLE OIL HOLE)	1	
4	04.005.11.0.00	BALANCE WT.	6	
5	04.005.12.0.00	SOCKET HEAD BOLT - M12X1.75X60 -10.9	12	
6	02.005.04.0.00	WASHER	12	
7	50.401.08.025	DOWEL PIN 8X25	1	
8	4H.002.01.0.00	CRANK SHAFT GEAR (FINISH/)	1	
9	50.401.08.065	DOWEL PIN 8X65	1	

TITLE: -CYLINDER HEAD

GROUP: - 6H.007

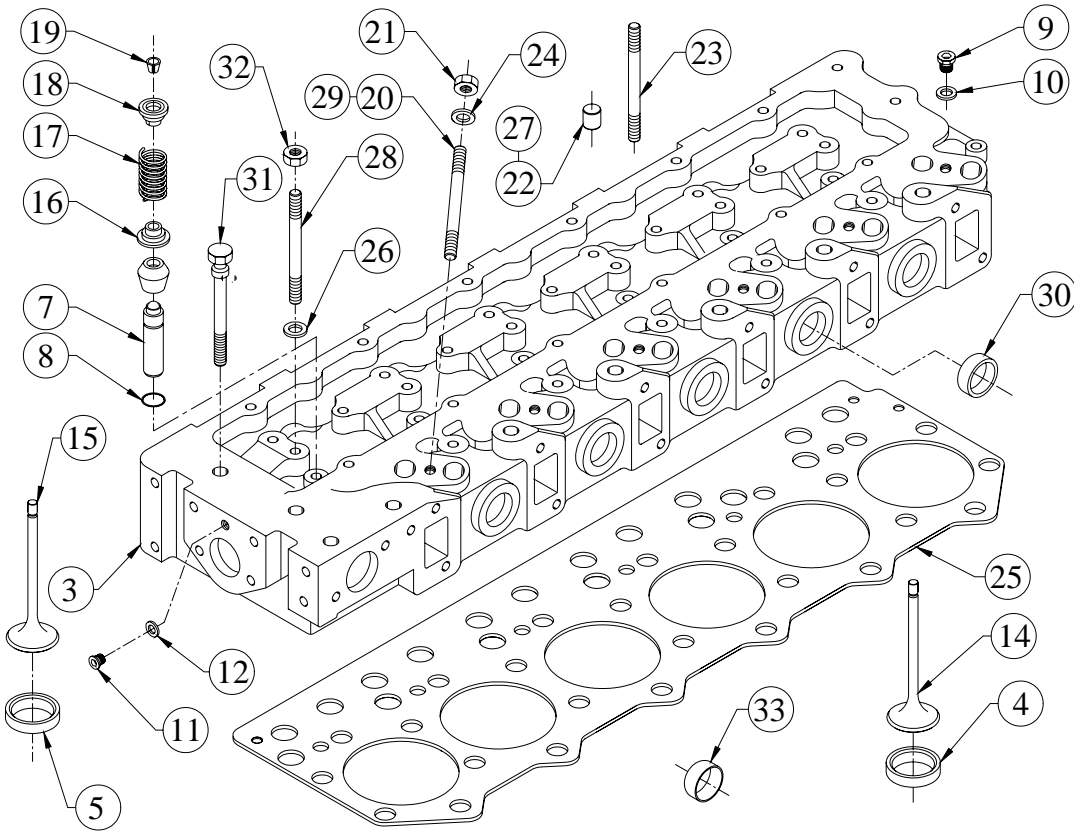

SR.NO.	PART NO.	DESCRIPTION	QTY.	REMARKS
*1	6H.007.10.0.00	CYLINDER HEAD ASSLY	1	CONSISTING OF SR. NO.- 2, 13 TO 25
*2	6H.007.20.0.00	CYL. HEAD WITH VALVE GUIDE & VALVE SEAT INSERT	1	CONSISTING OF SR. NO.- 3 TO 6, 9 TO 12
3	6H.007.01.0.00	CYL.HEAD	1	
4	4H.007.03.0.00	VALVE SEAT INSERT (INLET)	6	
5	4H.007.04.0.00	VALVE SEAT INSERT (EXHAUST)	6	
*6	4H.007.38.0.00	ASSEMBLY OF SEMIFINISH VALVE GUIDE & SNAP RING	12	CONSISTING OF SR. NO.- 7 & 8
7	4H.007.02.9.00	VALVE GUIDE (SEMI-FINISH)	1	
8	02.022.18.0.00	WIRE SNAP RING	1	
9	50.610.16.000.	CORE PLUG-HEXAGONAL SOCKET HEAD (DIN-908)	1	
10	50.508.16.000	COPPER WASHER (18X22)	1	
11	50.610.24.000	CORE PLUG	5	
12	50.508.29.000	COPPER WASHER (26X32)	5	

TITLE: -CYLINDER HEAD

GROUP: - 6H.007

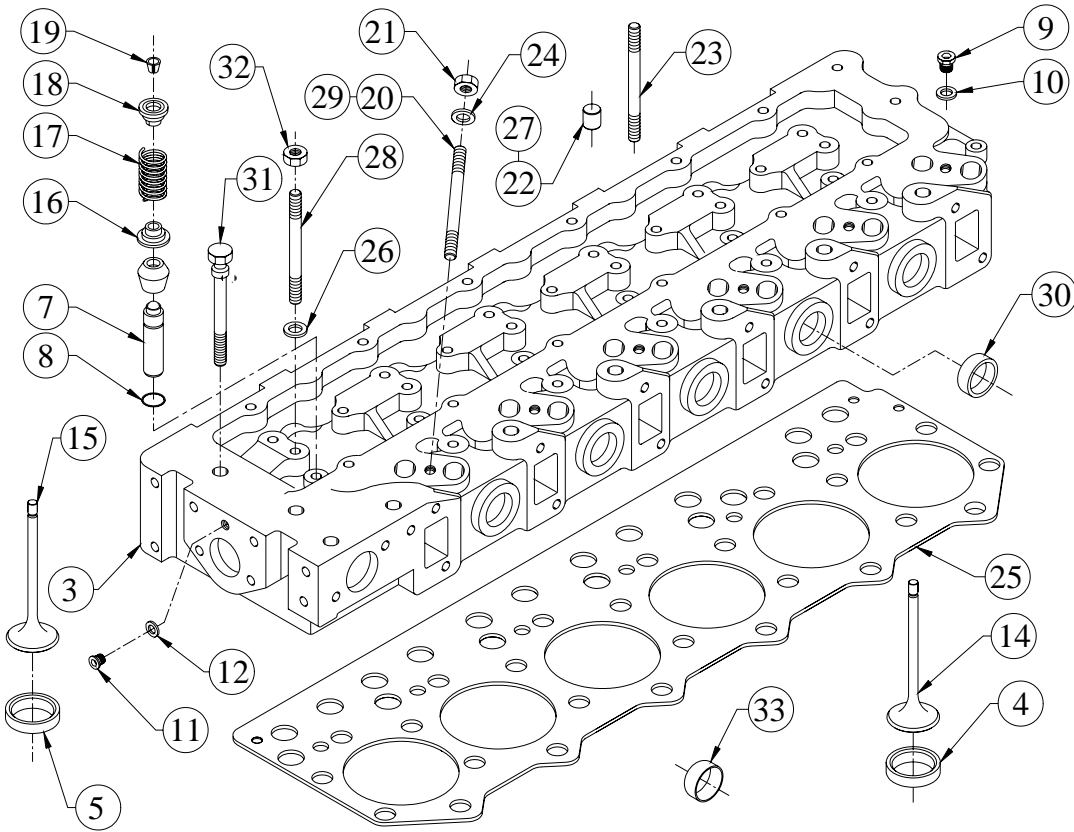

SR.NO.	PART NO.	DESCRIPTION	QTY.	REMARKS
*13	4H.007.40.0.00	INLET & EXHAUST VALVE PAIR	1	CONSISTING OF SR. NO.- 14 & 15
14	4H.007.05.0.00	INLET VALVE.	6	
15	4H.007.06.0.00	EXHAUST VALVE.	6	
16	34.013.13.0.00	CUP FOR VALVE SPRING.	12	
17	02.022.13.0.00	VALVE SPRING	12	
18	02.022.11.0.00	VALVE CUP	12	
19	02.022.12.0.00	VALVE COLLET	12	
20	50.010.10.050	STUD - M10X1.5X50 - 8.8	6	
21	50.006.10.000.	NUT - M10X1.5 - GR.8	12	
22	4H.007.08.0.00	BUTTON FOR INJECTOR YOKE.	6	
23	50.010.10.075	STUD - M10X1.5X75 - 8.8	6	
24	02.022.06.0.00	WASHER	6	
25	6H.007.06.0.00	GASKET (FOR CYL.HEAD)-1.22 MM THK.	1	
26	50.506.10.000.	PLAIN MACHINED WASHER - M10	12	
27	4H.007.08.0.00	BUTTON FOR INJECTOR YOKE.	6	
28	50.010.10.070	STUD - M10X1.5X70 - 8.8	6	

TITLE:- DELIVERY BODY

GROUP:- 2H.013...EXP

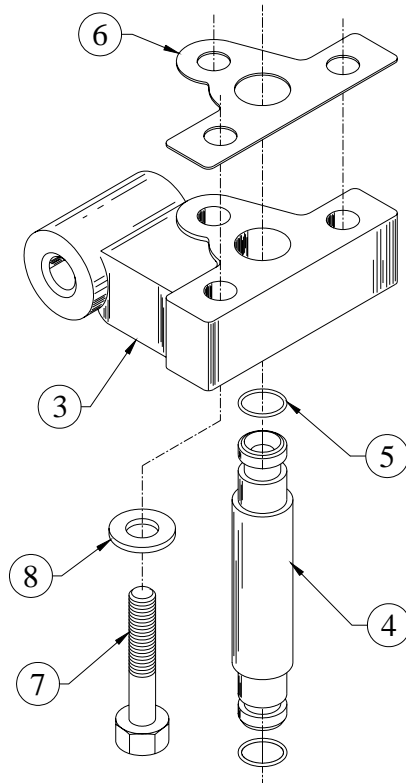

SR.NO.	PART NO.	DESCRIPTION	QTY.	REMARKS
*1	2H.013.20.0.00	DELIVERY BODY AND JOINT (NON ASBESTOS)	1	CONSISTING OF SR. NO. 2 & 6
*2	2H.013.10.0.00	DELIVERY BODY ASSEMBLY	1	CONSISTING OF SR. NO. 3 TO 5
3	2H.013.01.0.00	DELIVERY BODY (FINISH)	1	
4	2H.014.01.0.00	DELIVERY TUBE	1	
5	2H.014.02.0.00	O RING (FOR DELIVERY TUBE)	2	
6	2H.013.11.0.00	JOINT FOR DELIVERY BODY	1	
7	50.002.08.045.	SET BOLT - M8X1.25X45 - 8.8	3	
8	50.506.08.000.	PLAIN MACHINED WASHER - M8	3	

TITLE :- DIP STICK (20DEG INCL SHORT)

GROUP :- 06.248

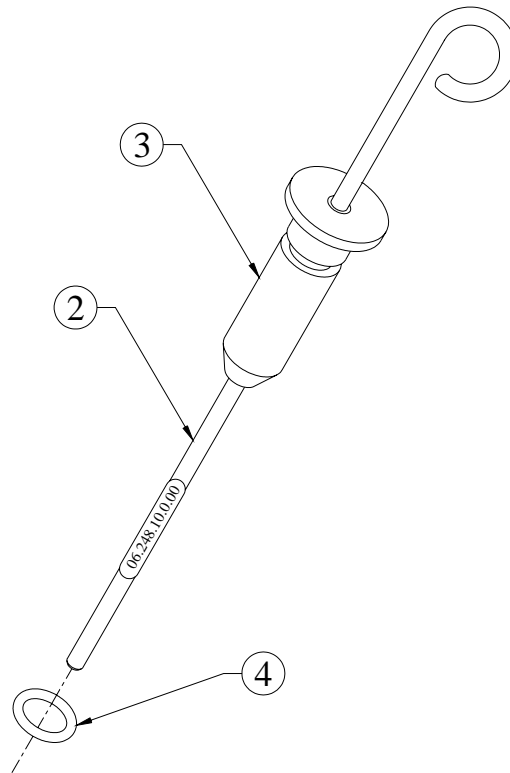

SR.NO.	PART NO.	DESCRIPTION	QTY.	REMARKS
*1	06.248.10.0.00	DIPSTICK ASSLY	1	CONSISTING OF SR. NO. 2 & 3
2	06.248.01.0.00	DIPSTICK ROD	1	
3	03.036.02.0.00	DIP STICK KNOB	1	
4	03.036.01.0.00	O RING - DIPSTICK (2X5, 21515 OR 21511)	1	

TITLE :- EXHAUST MANIFOLD

GROUP :- 6H.011

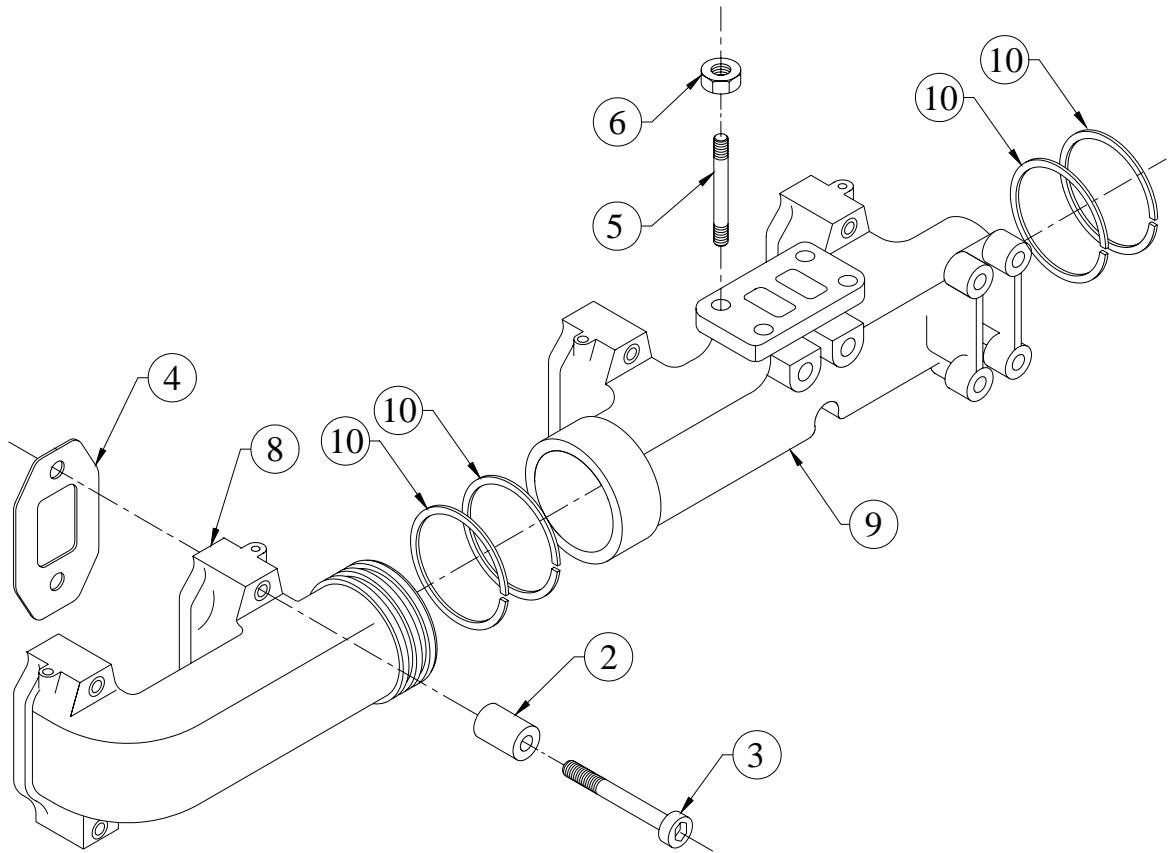

SR.NO.	PART NO.	DESCRIPTION	QTY.	REMARKS
*1	6H.011.10.0.00	EXHAUST MANIFOLD ASSLY. WITH RINGS	1	CONSISTING OF SR. NO. 8 TO 10
2	4H.107.02.0.00	SPACER (FOR EXT.MANIFOLD)	12	
3	50.011.08.075	SOCKET HEAD SCREW - M8X1.25X75 - 8.8	12	
4	4H.035.06.0.00	GASKET (FOR EXHAUST MANIFOLD)	6	
5	50.054.08.025	STUD-M8X25-10.9	4	
6	50.080.08.000	STAINLESS STEEL NUT	4	
7	50.506.08.000	PLAIN MACHINED WASHER - M8	4	
8	6H.011.01.0.00	EXHAUST MANIFOLD FINISH	2	
9	6H.011.02.0.00	EXHAUST MANIFOLD K26 TURBO	1	
10	F6.357.03.0.00	COMPRESSION RING	8	

TITLE :- FAN DRIVE ARRANGEMENT

GROUP :- 6H.031

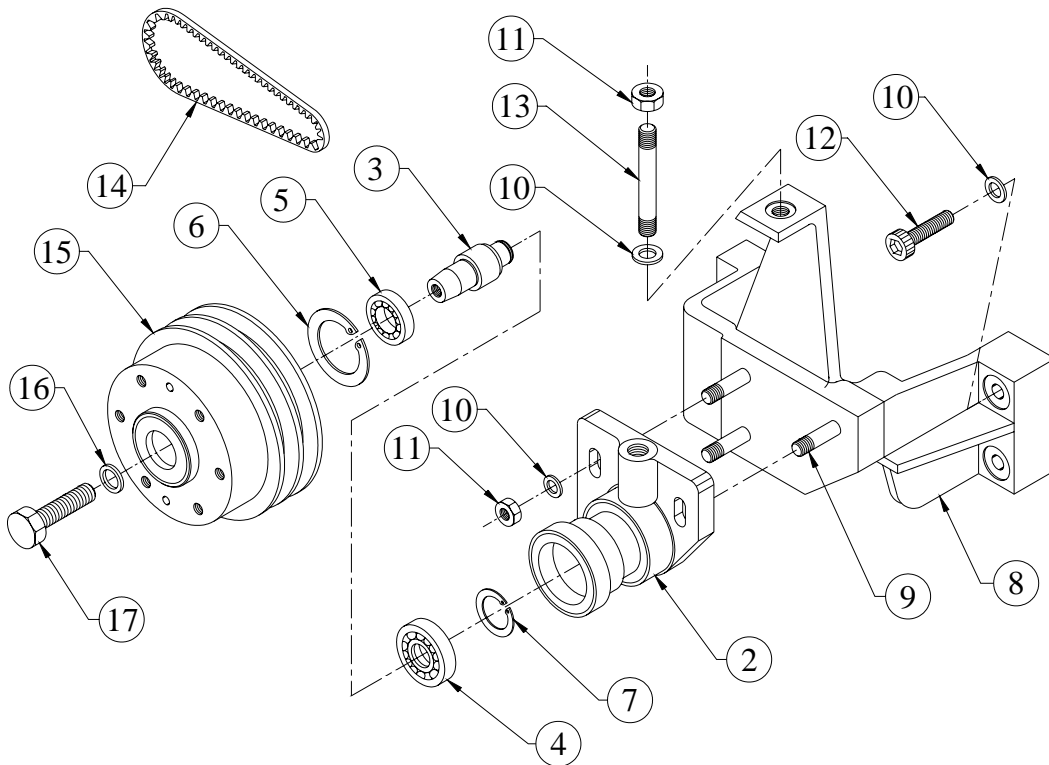

SR.NO.	PART NO.	DESCRIPTION	QTY.	REMARKS
*1	6H.031.10.0.00	SUB ASSEMBLY OF BEARING HOUSING	1	CONSISTING OF SR. NO.- 2 TO 7
2	6H.031.02.0.00	HOUSING FOR SHAFT (FINISH)	1	
3	6H.031.04.0.00	SHAFT FOR FAN PULLEY	1	
4	F6.017.21.0.00	BALL BEARING (DIN 625-6306-2RS1)	1	
5	F6.017.22.0.00	BALL BEARING (DIN 625 6305-2RS1)	1	
6	50.502.72.000	CIRCLIP INTERNAL - 72 MM	1	
7	50.501.25.000	CIRCLIP EXTERNAL - 25 MM	1	
8	6H.031.01.0.00	BRACKET (FINISH)	1	
9	50.010.10.025	STUD - M10X1.5X25 - 8.8	3	
10	50.506.10.000	PLAIN MACHINED WASHER - M10	7	
11	50.006.10.000	NUT - M10X1.5 - GR.8	4	
12	50.011.10.050	SOCKET HEAD SCREW - M10X1.5X50 - 8.8	4	
13	50.010.10.060	STUD - M10X1.5X60 - 8.8	1	
14	47.305.01.0.00	V BELT COGGED (BX-48)	2	

TITLE :- FLYWHEEL (HEAVY)

GROUP :- 6H.257

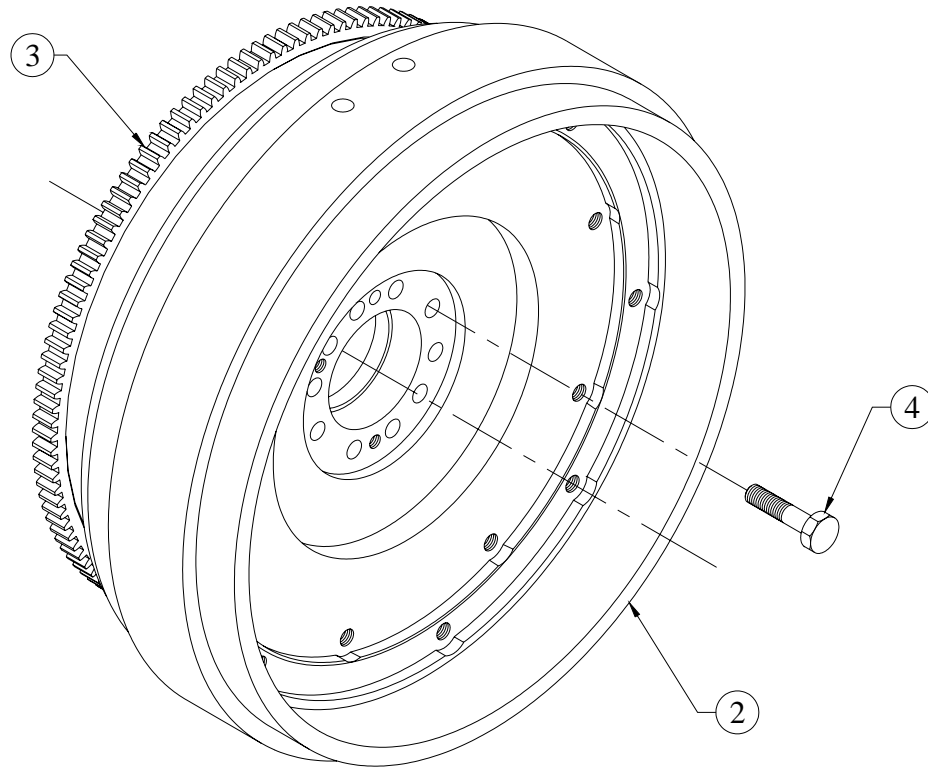

SR.NO.	PART NO.	DESCRIPTION	QTY.	REMARKS
*1	6H.257.10.0.00	FLYWHEEL ASSEMBLY	1	CONSISTING OF SR. NO. 2 & 3
2	6H.257.01.0.00	FLYWHEEL (FOR CC GENSET)	1	
3	03.035.02.0.00	STARTER RING HA	1	
4	04.024.02.0.00	BOLT FOR FLYWHEEL (M10X45 LONG)	10	

TITLE: - FLYWHEEL HOUSING (SAE3-144.5)

GROUP: - 4H.038

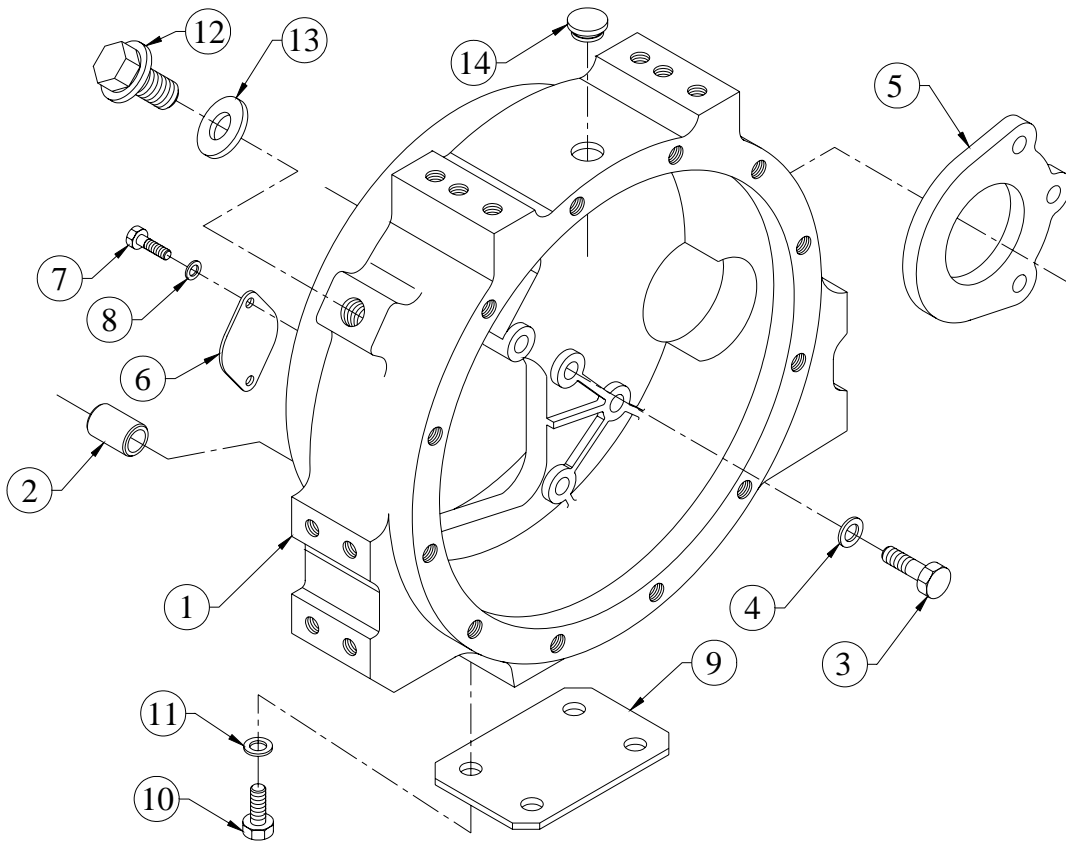

SR.NO.	PART NO.	DESCRIPTION	QTY.	REMARKS
1	4H.038.01.0.00	FLYWHEEL HOUSING (SAE3 -144.5)	1	
2	4H.001.13.0.00	HOLLOW DOWEL (16 DIA)	2	
3	50.052.10.030	SET BOLT-M10X30-10.9	10	
4	02.024.09.0.00	WASHER	10	
5	4H.038.02.0.00	FLANGE FOR STARTER.	1	
6	4H.038.04.0.00	BLANKING PLATE (FOR FLYWHEEL HOUSING)	1	
7	50.003.06.012	SET SCREW - M6X1X12 - 8.8	2	
8	50.506.06.000	PLAIN MACHINED WASHER - M6	2	
9	03.086.02.0.00	COVER FOR FLY WHEEL HSG	1	
10	50.003.08.016	SET SCREW - M8X1.25X16 - 8.8	4	
11	50.506.08.000	PLAIN MACHINED WASHER - M8	4	
12	50.602.16.000	CORE PLUG 16X1.5	1	
13	50.508.15.000	COPPER WASHER (17X23)	1	
14	F6.016.12.0.00	RUBBER CAP.	1	

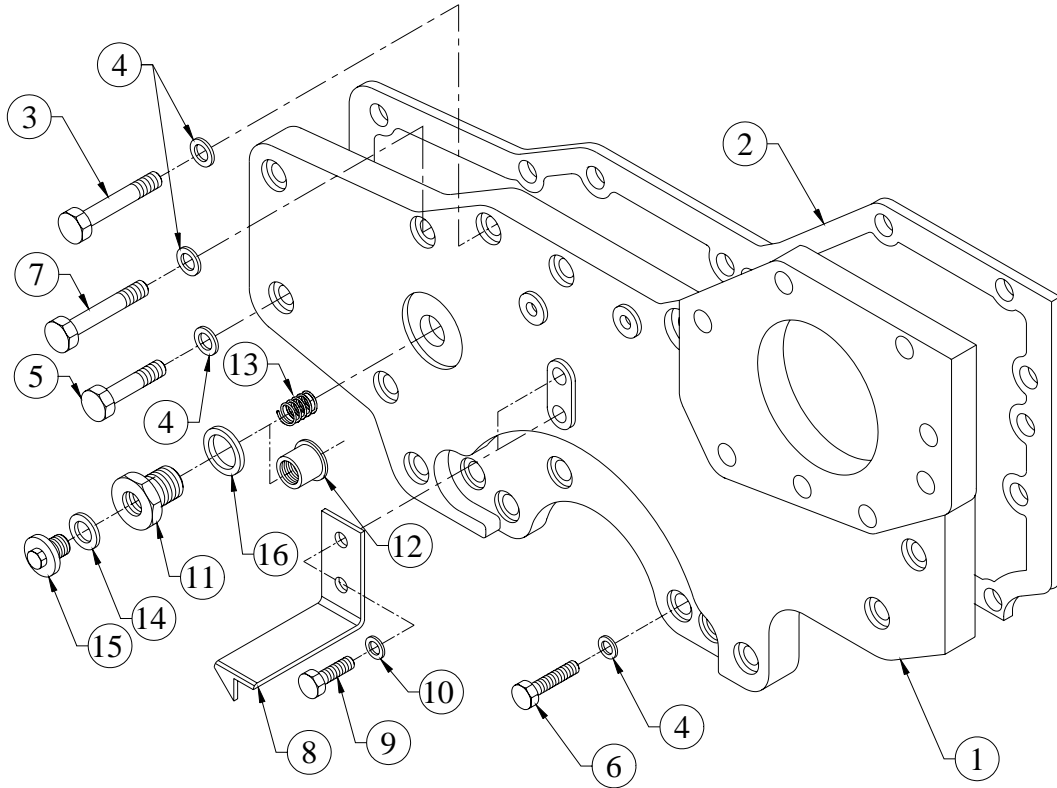
TOTAL: - FRONT COVER FOR PG APPLICATION**GROUP: - 4H.179...EXP**

SR.NO.	PART NO.	DESCRIPTION	QTY.	REMARKS
1	4H.179.01.0.00	FRONT COVER (W/O HYD. PUMP MNTG.)	1	
2	2H.037.11.0.00	JOINT (FRONT COVER)	1	
3	50.002.08.100	SET BOLT - M8X1.25X100 - 8.8	4	
4	50.506.08.000	PLAIN MACHINED WASHER - M8	18	
5	50.002.08.030	SET BOLT - M8X1.25X30 - 8.8	4	
6	50.003.08.025	SET SCREW - M8X1.25X25 - 8.8	5	
7	50.002.08.035	SET BOLT - M8X1.25X35 - 8.8	5	
8	2H.037.06.0.00	TIMING POINTER	1	
9	50.003.06.012	SET SCREW - M6X1X12 - 8.8	2	
10	50.506.06.000	PLAIN MACHINED WASHER - M6	2	
11	03.117.04.0.00	ADAPTOR (FOR TD UNIT)	1	
12	03.014.07.0.00	CUP FOR SPRING	1	
13	03.014.06.0.00	SPRING FOR CUP	1	
14	50.508.27.000	COPPER WASHER (24X29)	1	
15	34.001.11.0.00	DRAIN PLUG (F)	1	
16	50.508.16.000	COPPER WASHER (18 X 22)	1	

TITLE:- FUEL PUMP V.S. EXPORT

GROUP:- 6H.054...EXP

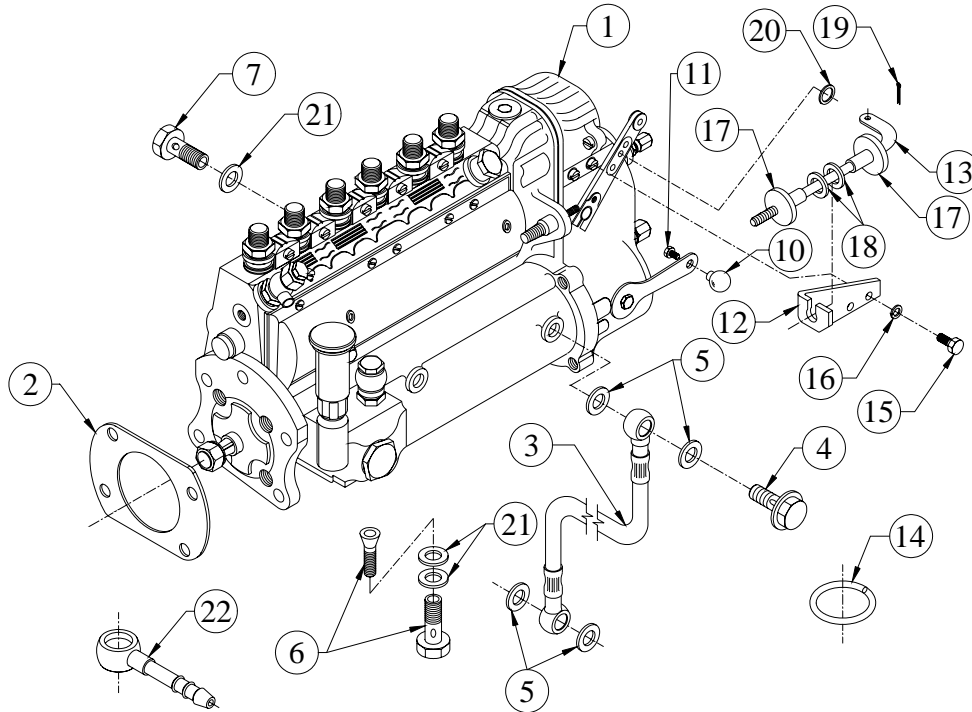

SR.NO.	PART NO.	DESCRIPTION	QTY.	REMARKS
1	6H.054.10.0.00	FUEL INJECTION PUMP(6TC,100 KVA - 1500 RPM MICO NO. F 002 AOZ 227)	1	
2	34.016.11.0.00	JOINT	1	
3	4H.006.01.0.00	L.O.SUPPLY HOSE (FIP)	1	
4	03.660.07.0.00	SPECIAL BANJO BOLT(L.O.SUPPLY TO PUMP)	2	
5	50.508.07.000.	COPPER WASHER (10X14)	4	
6	34.016.15.0.00	BANJO BOLT WITH STRAINER (2 443 456 900)	1	
7	50.504.04.000.	BANJO BOLT - M14X1.5	2	
*8	10.027.02.0.00	LEAD SEAL (5945010300)	1	NOT ILLUSTRATED
*9	10.027.03.0.00	SEALING WIRE (5945010600)	1	NOT ILLUSTRATED
10	51.509.25.0.00	KNOB FOR HANDLE	1	
11	50.003.06.012.	SET SCREW - M6X1X12 - 8.8	1	
12	4H.122.01.0.00	BRACKET FOR SPEED ADJUSTMENT	1	

TITLE:- FUEL PUMP V.S. EXPORT

GROUP:- 6H.054...EXP

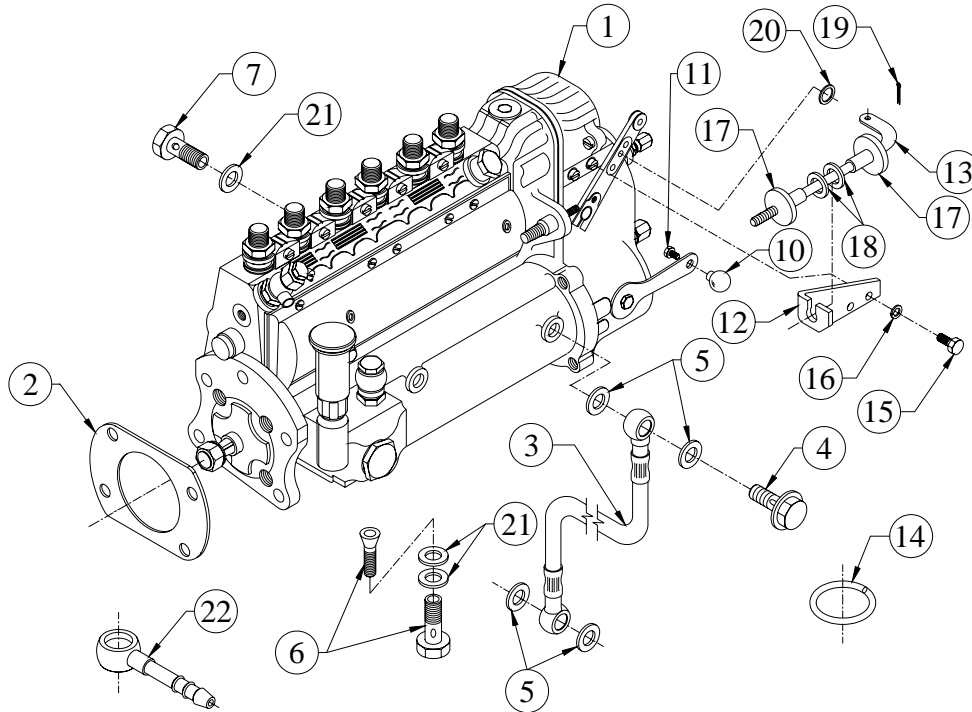

SR.NO.	PART NO.	DESCRIPTION	QTY.	REMARKS
13	4H.122.02.0.00	BAR FOR SPEED ADJUSTMENT	1	
14	03.036.01.0.00	O RING - DIPSTICK (2X5, 21515 OR 21511)	2	
15	50.003.06.015.	SET SCREW - M6X1X15 - 8.8	2	
16	50.505.06.000.	SPRING WASHER - M6	2	
17	03.065.04.0.00	KNURLED NUT	2	
18	03.065.05.0.00	SPHERICAL WASHER	2	
19	50.001.01.010.	SPLIT COTTER PIN - 1.6X10	1	
20	50.548.06.000.	WASHER	1	
21	50.565.14.000.	INTERNAL RUBBER LIP SEALING WASHER -M14- FOR FUEL LINES	6	
22	06.610.10.0.00	SUB ASSLY OF HOSE TAIL (M14 BANJO)	1	

TITLE :- GEAR CASING

GROUP :- 6H.020...EXP

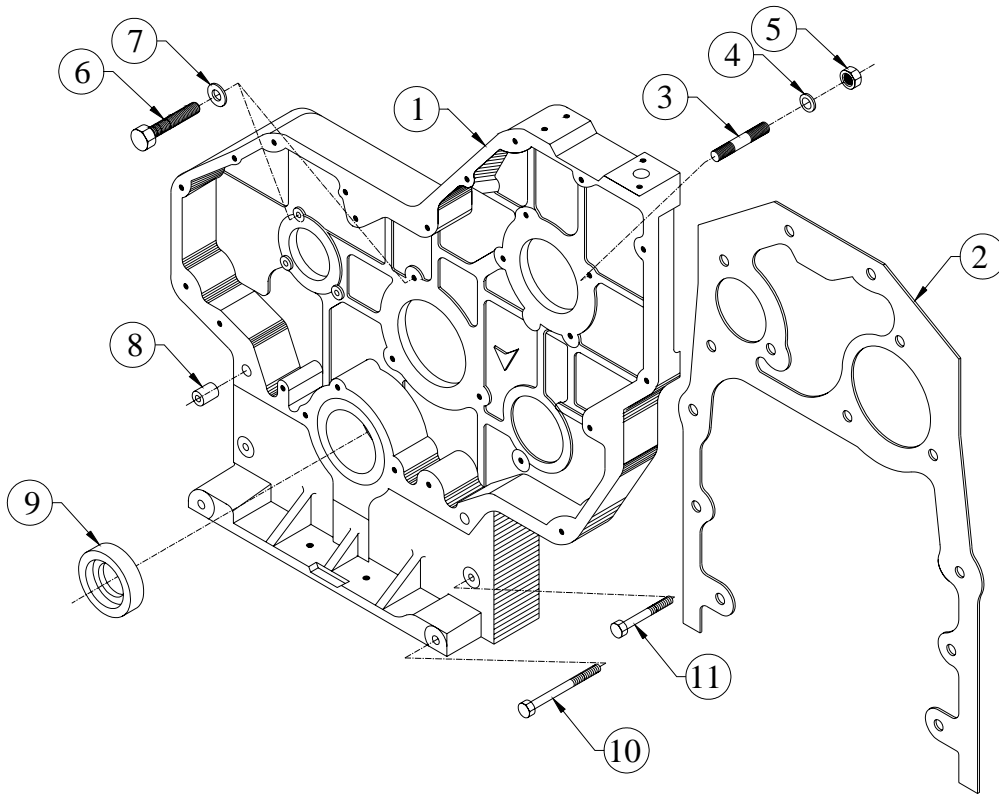

SR.NO.	PART NO.	DESCRIPTION	QTY.	REMARKS
1	6H.020.01.0.00	GEAR CASING	1	
2	6H.020.11.0.00	JOINT BETWEEN CRANKCASE AND GEAR COVER	1	
3	50.010.10.030	STUD - M10X1.5X30 - 8.8	4	
4	03.001.25.0.00	WASHER (FOR FUEL PUMP MTG)	4	
5	50.006.10.000	NUT - M10X1.5 - GR.8	4	
6	50.003.08.025	SET SCREW - M8X1.25X25 - 8.8	8	
7	50.506.08.000	PLAIN MACHINED WASHER - M8	14	
8	34.001.23.0.00	DOWEL FOR GEAR CASING	2	
9	03.013.06.0.00	OIL SEAL (65X85X13)(CR MAKE)	1	
10	50.002.08.110	SET BOLT - M8X1.25X110 - 8.8	2	
11	50.002.08.080	SET BOLT - M8X1.25X80 - 8.8	2	

TITLE :- HIGH PRESSURE PIPE (700MM)

GROUP :- 6H.009

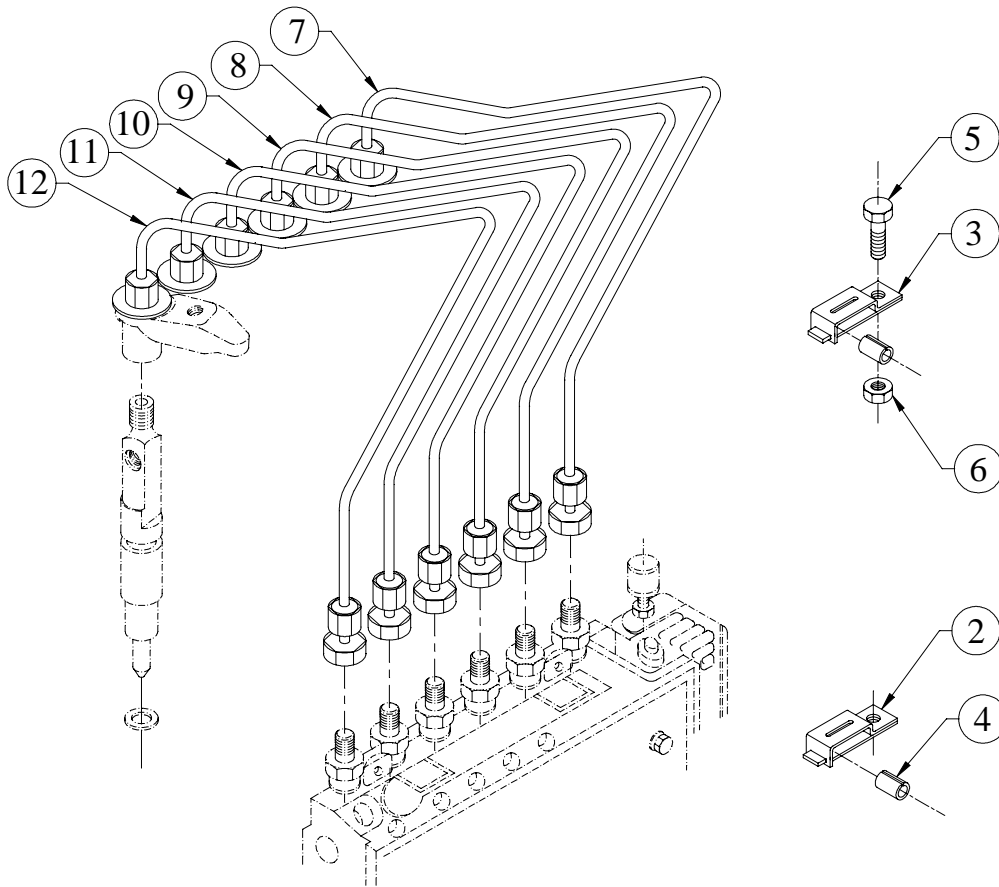

SR.NO.	PART NO.	DESCRIPTION	QTY.	REMARKS
*1	6H.009.70.0.00	H.P. PIPE--COMPLETE SET	1	CONSISTING OF SR. NO. 7 TO 12
2	50.541.02.000	PIPE CLIP. (FOR 3 PIPES)	2	
3	50.541.03.000	PIPE CLIP (FOR 4 PIPES)	2	
4	02.036.03.0.00	RUBBER SLEEVE	14	
5	50.003.06.012	SET SCREW - M6X1X12 - 8.8	4	
6	50.006.06.000	NUT - M6X1 - GR.8	4	
7	6H.009.10.0.00	H.P. PIPE ASSLY. (CYL. NO.1)	1	
8	6H.009.20.0.00	H.P. PIPE ASSLY. (CYL. NO.2)	1	
9	6H.009.30.0.00	H.P. PIPE ASSLY. (CYL. NO.3)	1	
10	6H.009.40.0.00	H.P. PIPE ASSLY. (CYL. NO.4)	1	
11	6H.009.50.0.00	H.P. PIPE ASSLY. (CYL. NO.5)	1	
12	6H.009.60.0.00	H.P. PIPE ASSLY. (CYL. NO.6)	1	

**TITLE :- INTERMEDIATE GEAR AND SUPPORT
(FOR ENGINE W/O AUTOTIMER)**

GROUP :- 4H.237

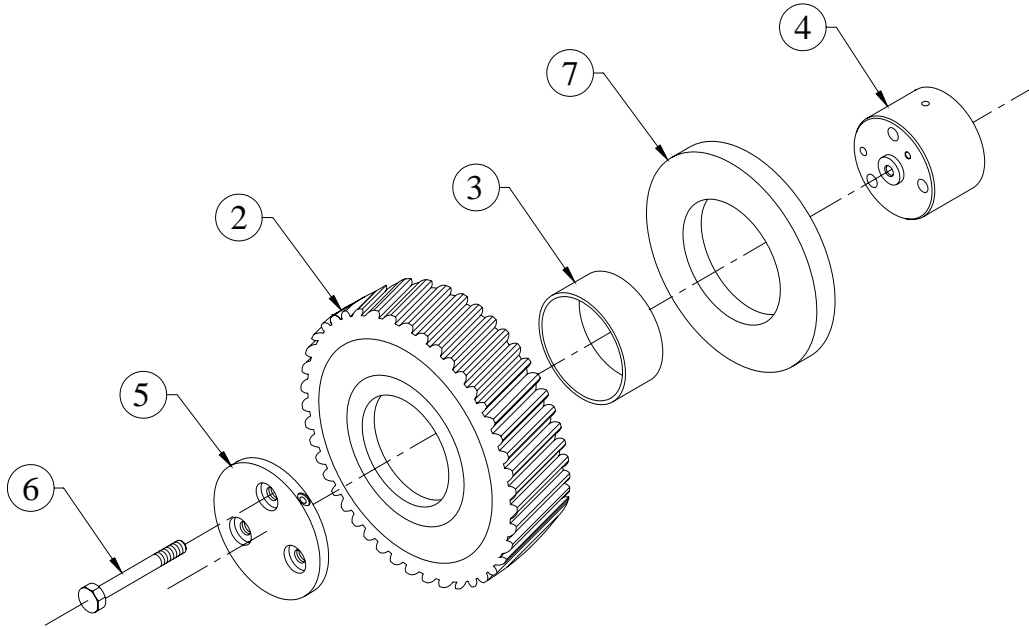

SR.NO.	PART NO.	DESCRIPTION	QTY.	REMARKS
*1	2H.038.10.0.00	ASSLY OF INTERMEDIATE GEAR & BUSH	1	CONSISTING OF SR.NO. 2 & 3
2	2H.038.03.0.00	INTERMEDIATE GEAR (FINISH)	1	
3	2H.004.02.9.00	BUSH FOR INTERMEDIATE GEAR (S/F)	1	
4	4H.237.01.0.00	INTERMEDIATE GEAR SUPPORT (TURBO W/O AUTOTIMER)	1	
5	2H.004.04.0.00	RETAINING PLATE (FOR INT.GEAR)	1	
6	50.002.08.070	SET BOLT - M8X1.25X70 - 8.8	3	
7	2H.038.02.0.00	THRUST WASHER	1	

TITLE :- LUB OIL COOLER (EXPORT)

GROUP :- 6H.014...EXP

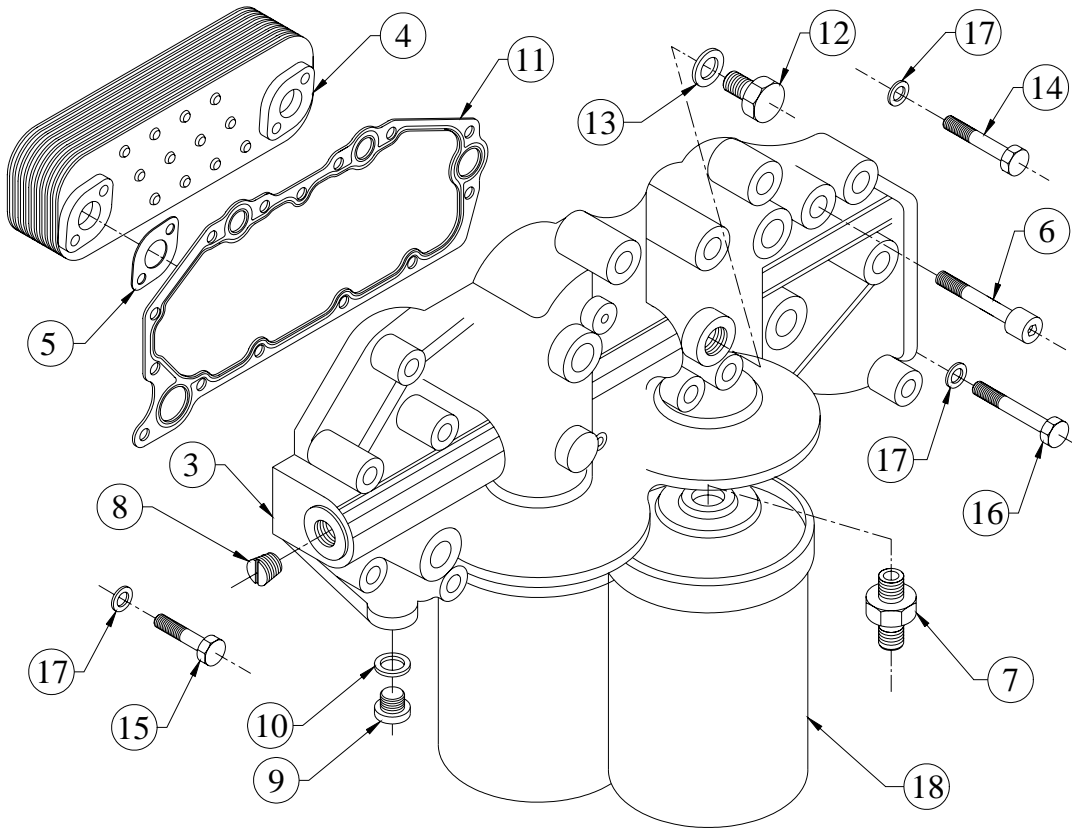

SR.NO.	PART NO.	DESCRIPTION	QTY.	REMARKS
*1	6H.014.30.0.00	LUB OIL COOLER ASSLY.	1	CONSISTING OF SR. NO. 2, 11 TO 17
*2	6H.014.20.0.00	HEADER & COOLER ASSLY.	1	CONSISTING OF SR. NO. 3 TO 10
3	6H.014.03.0.00	HEADER (FOR L.O.COOLER & SPIN ON FILTER)	1	
4	F6.358.01.0.00	PLATE TYPE LUB OIL COOLER	1	
5	F6.036.07.0.00	JOINT FOR LUB OIL COOLER	1	
6	50.011.10.040.	CZ AP SCREW	4	
7	3H.007.05.0.00	ADAPTOR FOR SPIN ON FILTER	2	
8	50.056.07.000	HEADLESS PIPE PLUG (NPTF 14-3/4")	1	
9	50.610.22.000	ALLEN PLUG	1	
10	50.508.23.000	COPPER WASHER (22X27)	1	
11	6H.014.11.0.00	JOINT (FOR HEADER)	1	
12	34.001.09.0.00	PLUG FOR OIL GALLERY	1	

TITLE :- LUB OIL COOLER & SPIN ON TYPE FILTER

GROUP :- 6H.014

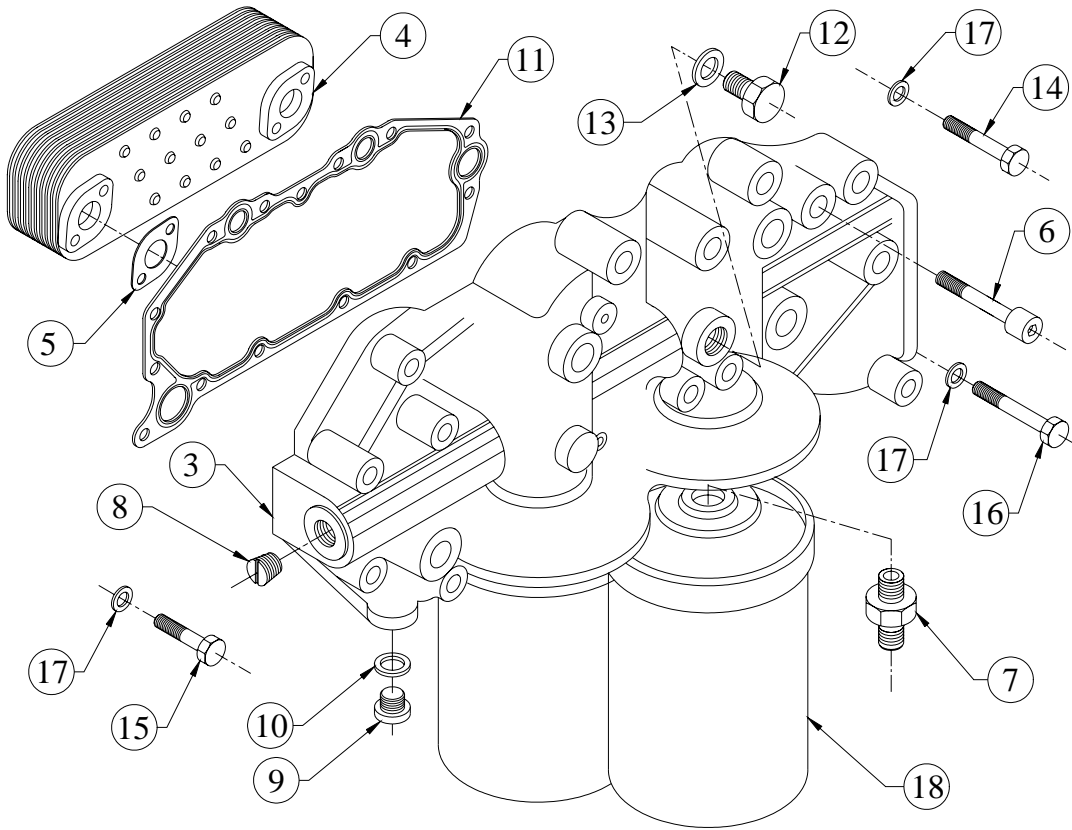

SR.NO.	PART NO.	DESCRIPTION	QTY.	REMARKS
13	50.565.10.000	INTERNAL RUBBER LIP SEALING WASHER -M10- FOR FUEL LINES	1	
14	50.002.08.060	SET BOLT - M8X1.25X60 - 8.8	2	
15	50.002.08.090	SET BOLT - M8X1.25X90 - 8.8	4	
16	50.002.08.115	SET BOLT - M8X1.25X115 - 8.8	8	
17	50.506.08.000	PLAIN MACHINED WASHER - M8	14	
18	06.436.01.0.00	SPIN ON FILTER FOR LUBRICATING OIL	2	

TITLE :- LUB OIL PUMP

GROUP :- 6H.047

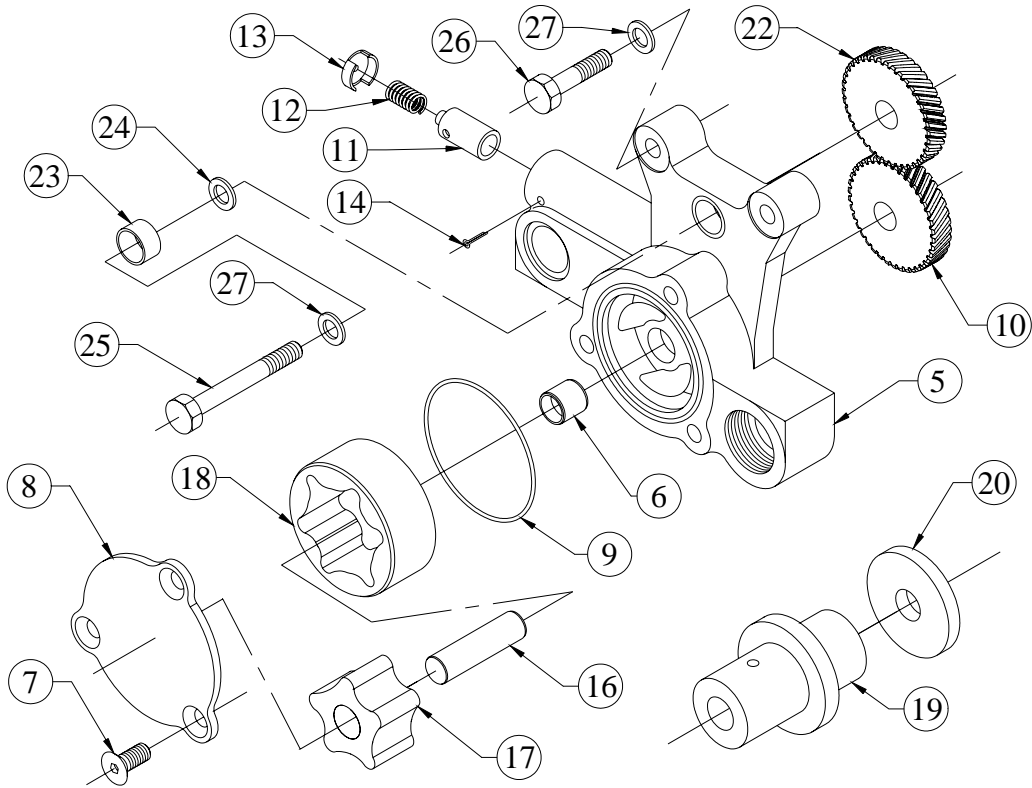

SR.NO.	PART NO.	DESCRIPTION	QTY.	REMARKS
*1	6H.047.40.0.00	LUB OIL PUMP ASSLY WITH INTERMEDIATE GEAR	1	CONSISTING OF SR. NO.- 2, 19 TO 21 & 24
*2	6H.047.30.0.00	LUB OIL PUMP ASSLY	1	CONSISTING OF SR. NO.- 3, 15, 18, 9 TO 14
*3	6H.047.90.0.00	LUB OIL PUMP ASSEMBLY (WITHOUT ROTORS)	1	CONSISTING OF SR. NO.- 4, 7 TO 14
*4	6H.047.20.0.00	SUBASSLY OF LUB OIL PUMP BODY & BUSH	1	CONSISTING OF SR. NO.- 5 AND 6
5	6H.047.01.0.00	LUB OIL PUMP BODY (MACHINING)	1	
6	03.010.05.0.00	BUSH FOR L.O.PUMP BODY	1	
7	06.010.01.0.00	COUNTER SUNK SOCKET HEAD SCREW.	2	
8	06.010.02.0.00	COVER PLATE	2	

TITLE :- LUB OIL PUMP

GROUP :- 6H.047

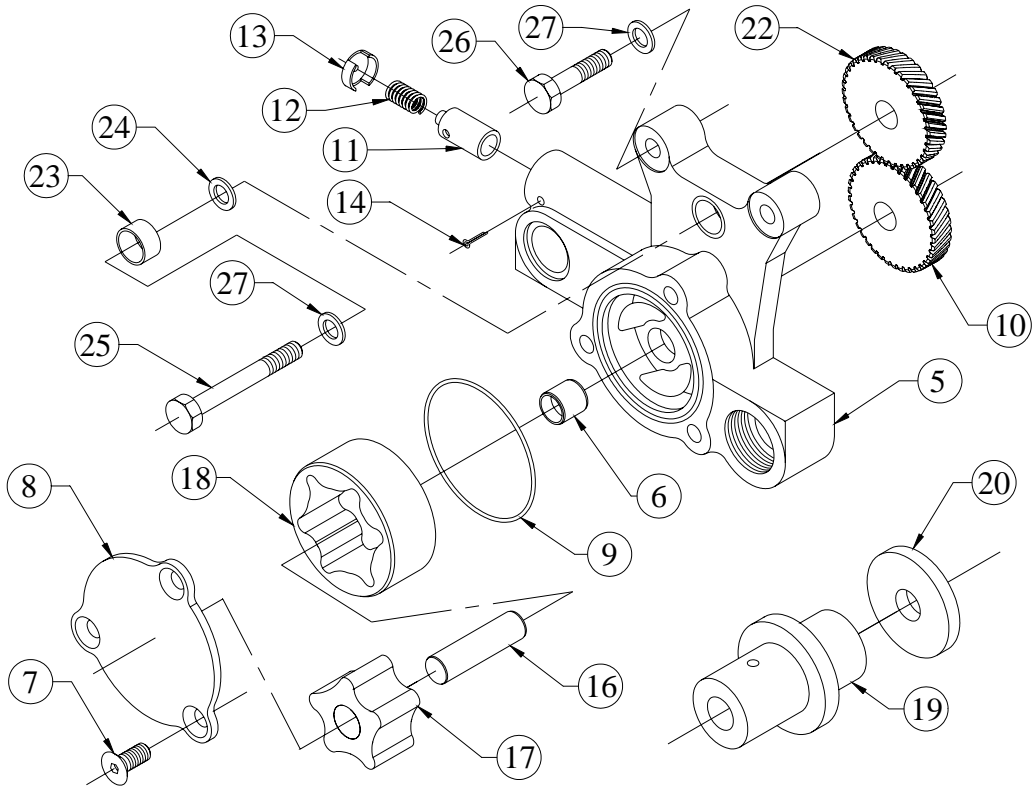

SR.NO.	PART NO.	DESCRIPTION	QTY.	REMARKS
9	03.010.11.0.00	O RING - L.O.PUMP (1.57X65, 21508)	2	
10	3H.005.04.0.00	LUB.OIL PUMP DRIVING GEAR (FINISH)	2	
11	03.010.13.0.00	RELIEF VALVE	2	
12	03.010.14.0.00	SPRING FOR RELIEF VALVE	2	
13	03.010.15.0.00	CUP FOR SPRING	2	
14	50.036.07.010	SPLIT COTTER PIN - 1/8"X1-1/2"	2	
*15	6H.047.10.0.00	ROTOR SUBASSLY	1	CONSISTING OF SR. NO.- 16 AND 17
16	6H.047.02.0.00	SHAFT FOR INNER ROTOR	1	
17	6H.047.03.0.00	INNER ROTOR	1	
18	6H.047.04.0.00	OUTER ROTOR	1	
19	4H.372.01.0.00	SHAFT FOR LUB OIL PUMP (INTERMEDIATE GEAR)	1	
20	4H.372.02.0.00	HARD WASHER (FOR INT. GEAR)	1	
*21	3H.005.30.0.00	SUB.ASSLY.OF L.O.PUMP INT.GEAR AND BUSH.	1	CONSISTING OF SR. NO.- 22 AND 23

TITLE :- LUB OIL PUMP

GROUP :- 6H.047

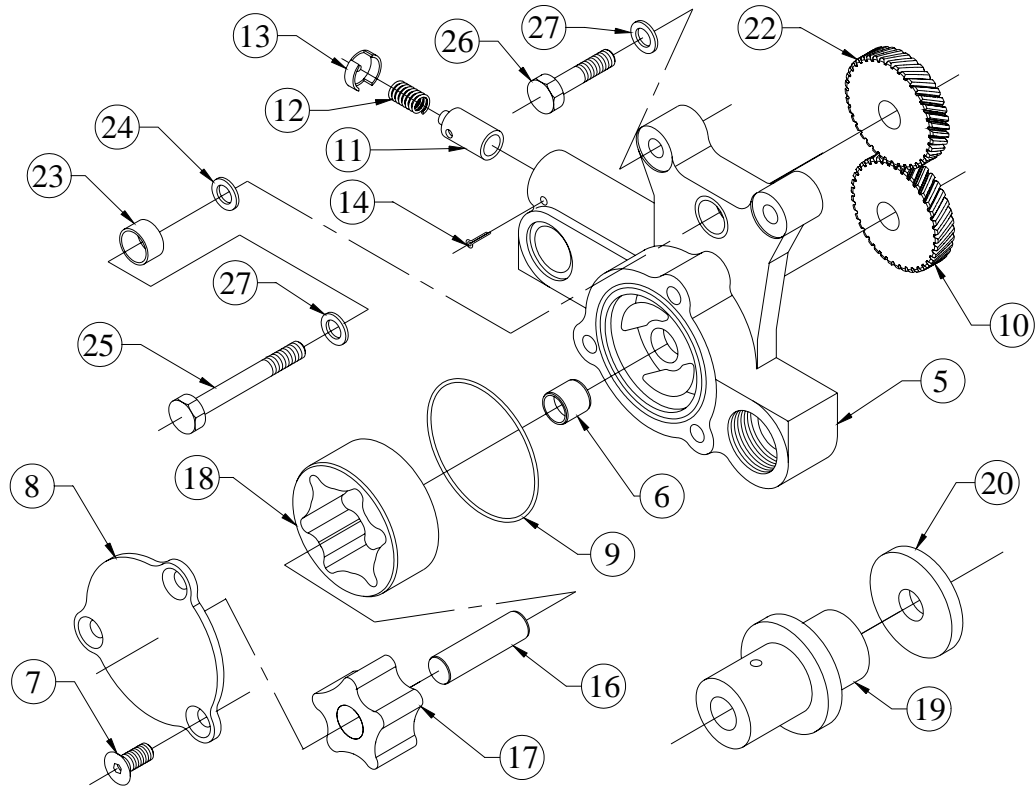

SR.NO.	PART NO.	DESCRIPTION	QTY.	REMARKS
22	3H.005.03.0.00	INTERMEDIATE GEAR (FOR L.O.PUMP) (FINISH)	1	
23	34.014.12.0.00	BUSH FOR LEVER	1	
24	02.024.38.0.00	WASHER (ROCKER LEVER)	1	
25	50.002.08.075	SET BOLT - M8X1.25X75 - 8.8	1	
26	50.002.08.035	SET BOLT - M8X1.25X35 - 8.8	2	
27	50.506.08.000	PLAIN MACHINED WASHER - M8	3	

TITLE :- MONOBLOCK CRANKCASE

GROUP :- 6H.001

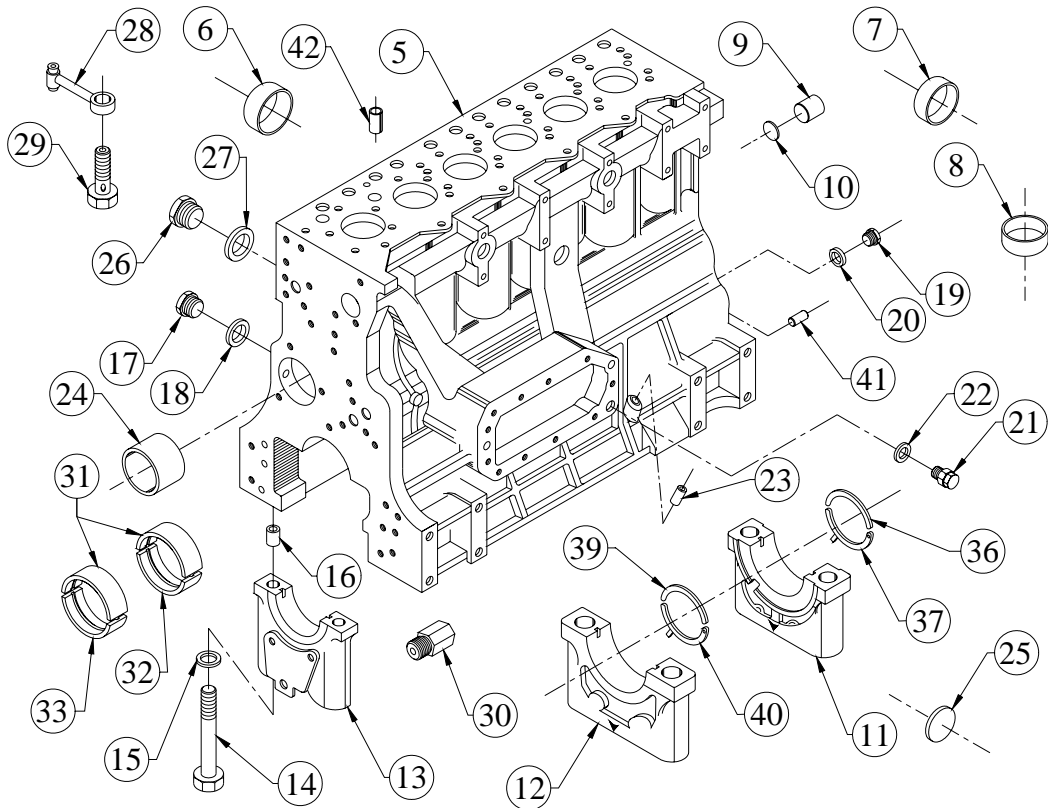

SR.NO.	PART NO.	DESCRIPTION	QTY.	REMARKS
*1	6H.001.10.0.00	MONOBLOCK CRANK CASE WITHOUT BEARINGS	1	CONSISTING OF SR. NO.- 2, 24 TO 30
*2	6H.001.20.0.00	MONOBLOCK CRANKCASE AND BEARING CAP ASSLY	1	CONSISTING OF SR. NO.- 3 AND 23
*3	6H.001.30.0.00	MONOBLOCK CRANKCASE WITH SEALING CAP	1	CONSISTING OF SR. NO.- 4, 17 TO 22
*4	6H.001.40.0.00	MONOBLOCK CRANK CASE SUB ASSLY	1	CONSISTING OF SR. NO.- 5 TO 16
5	6H.001.25.0.00	MONOBLOCK CRANKCASE	1	
6	F6.007.34.0.00	SEALING CAP	4	
7	F6.001.58.0.00	SEALING CAP. (40 DIN 443)	3	
8	4H.001.05.0.00	SEALING CAP (52 DIN 443)	4	
9	34.003.07.0.00	CRANK SHAFT PLUG – ALUMINIUM	2	

TITLE :- MONOBLOCK CRANKCASE

GROUP :- 6H.001

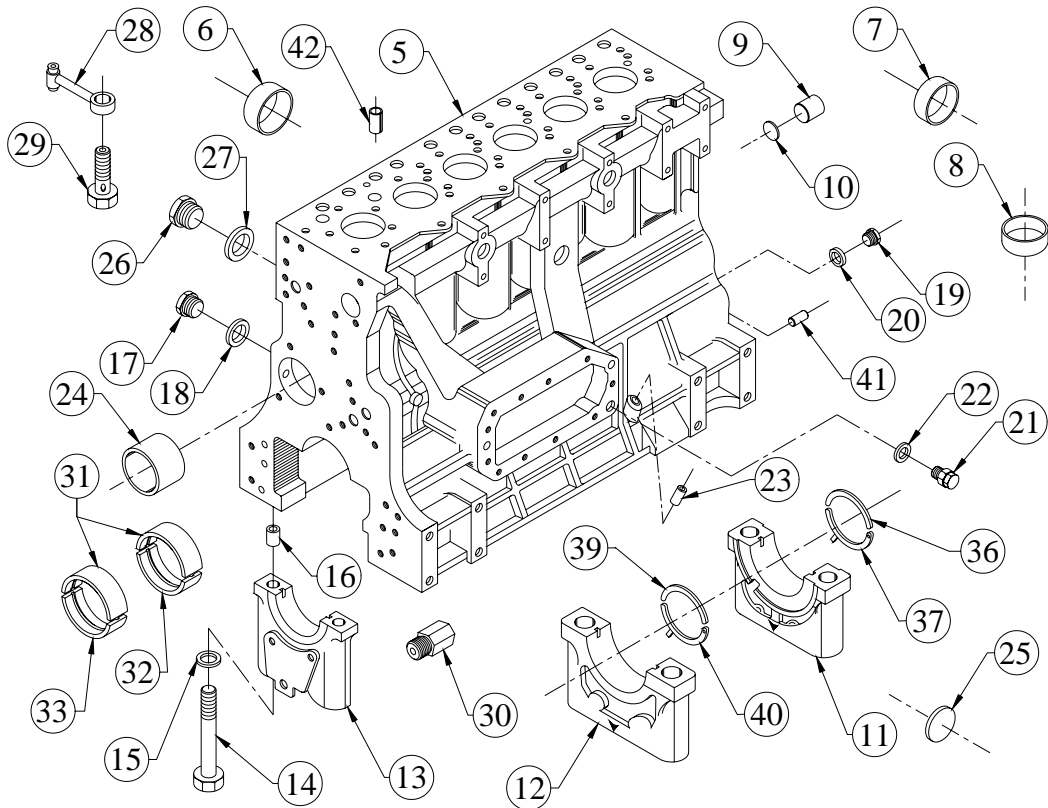

SR.NO.	PART NO.	DESCRIPTION	QTY.	REMARKS
10	34.003.08.0.00	WASHER FOR ALU.PLUG.	2	
11	6H.001.06.0.00	MAIN BEARING CAP (FLYWHEEL END)	1	
12	6H.001.08.0.00	MAIN BEARING CAP	5	
13	6H.001.07.0.00	MAIN BEARING CAP (FINISH) G.E.	1	
14	03.001.22.0.00	BOLT FOR MB CAP (HEX HEAD) M14X2X128	14	
15	02.001.04.0.00	WASHER	14	
16	B2.005.16.0.00	HOLLOW DOWEL (M.B.CAP)	14	
17	50.610.12.000.	CORE PLUG	1	
18	50.508.10.000.	COPPER WASHER (12X18)	1	
19	04.001.04.0.00	SCREW PLUG (M20 X 1.5)	2	
20	50.508.18.000.	COPPER WASHER (20X24)	2	
21	03.001.06.0.00	SCREW PLUG	2	
22	50.508.14.000.	COPPER WASHER (16X22)	2	
23	02.037.04.0.00	DIPSTICK GUIDE	1	
24	03.001.04.0.00	CAM BUSH	1	
25	02.001.13.0.00	DISC PLUG	1	

TITLE :- MONOBLOCK CRANKCASE

GROUP :- 6H.001

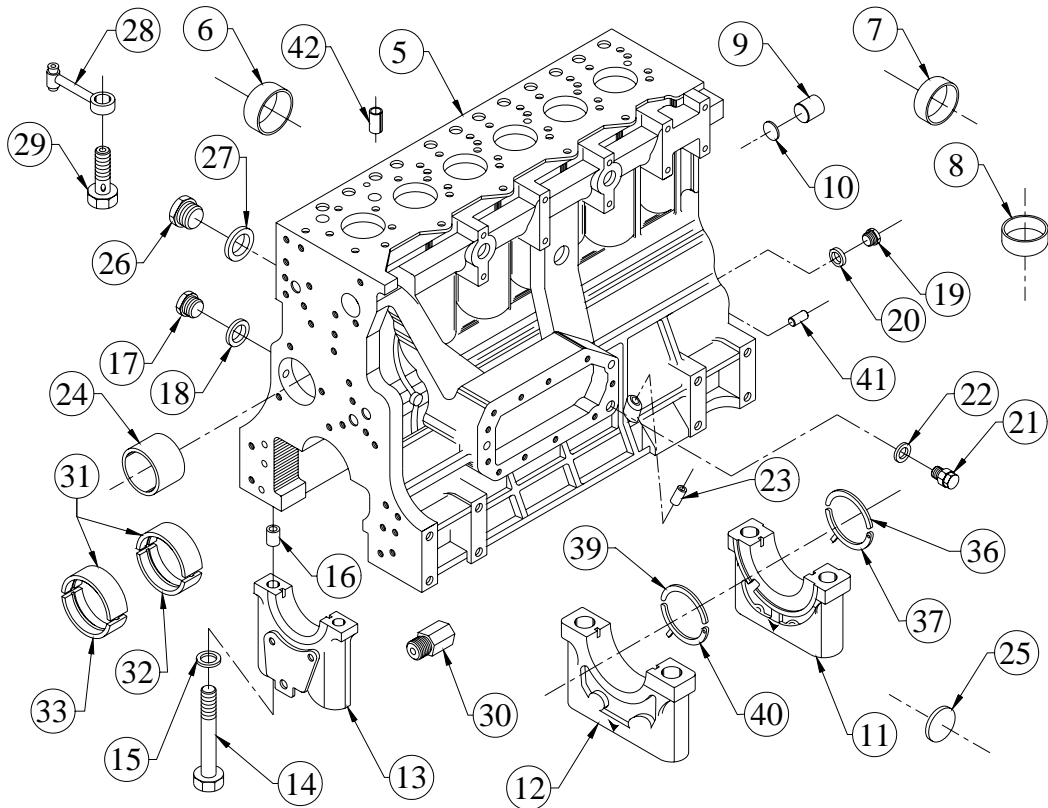

SR.NO.	PART NO.	DESCRIPTION	QTY.	REMARKS
26	50.610.14.000	CORE PLUG-HEXAGONAL SOCKET HEAD (DIN-908)	5	
27	50.565.14.000	INTERNAL RUBBER LIP SEALING WASHER -M14- FOR FUEL LINES	6	
28	6H.001.17.0.00	PISTON COOLING NOZZLE ASSLY.	6	
29	4H.156.07.0.00	SUB. ASSEMBLY OF SPECIAL BANJO BOLT (FOR OIL SPRAY NOZZLE.)	6	
30	6H.001.21.0.00	ADAPTER FOR LUB OIL TEMP. SWITCH	1	
31	6H.001.18.0.00	MAIN BEARING (TOP)	7	
32	6H.001.19.0.00	MAIN BEARING (BOTTOM)	6	
33	6H.001.02.0.00	MAIN BEARING (BOTTOM- GEAR END)	1	
*34	6H.001.05.0.00	THRUST WASHER SET OF INNER & OUTER PAIRS	1	CONSISTING OF SR. NO.- 35 AND 38

TITLE :- MONOBLOCK CRANKCASE

GROUP :- 6H.001

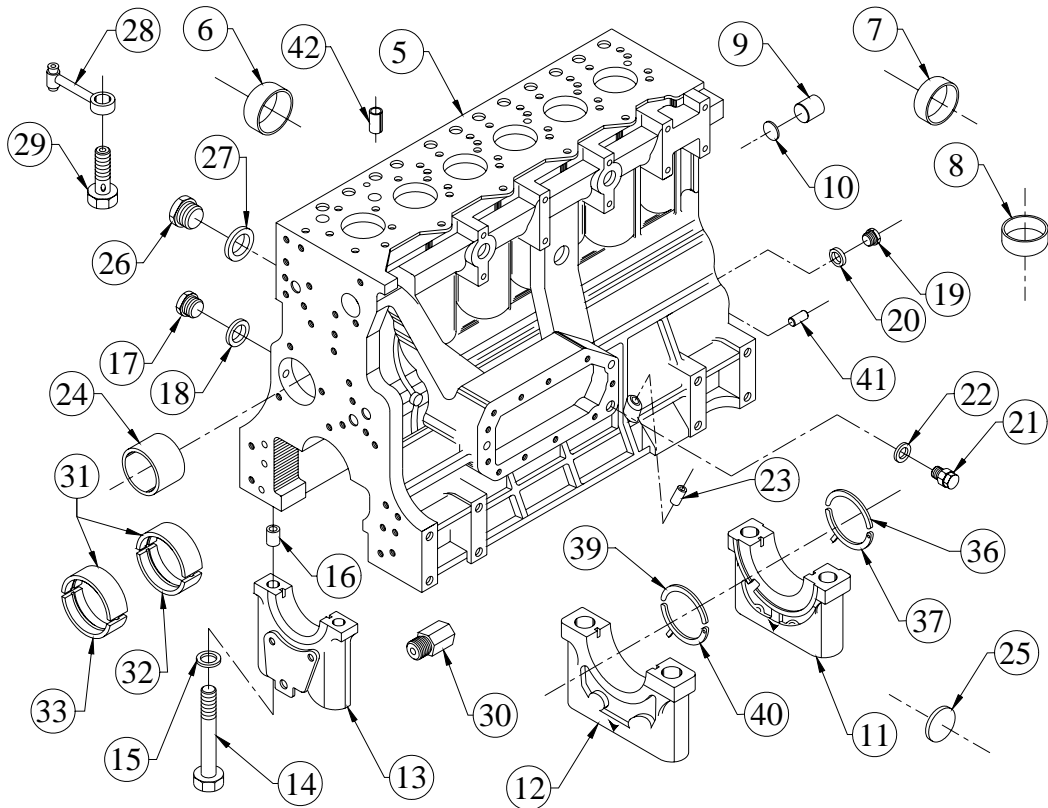

SR.NO.	PART NO.	DESCRIPTION	QTY.	REMARKS
*35	6H.001.03.0.00	THRUST WASHER PAIR (INNER)	1	CONSISTING OF SR. NO.- 36 AND 37
36	6H.001.09.0.00	THRUST WASHER (INNER) TOP SIDE	1	
37	6H.001.11.0.00	THRUST WASHER (INNER) BOTTOM SIDE	1	
*38	6H.001.04.0.00	THRUST WASHER PAIR (OUTER)	1	CONSISTING OF SR. NO.- 39 AND 40
39	6H.001.12.0.00	THRUST WASHER (OUTER) TOP SIDE	1	
40	6H.001.13.0.00	THRUST WASHER (OUTER) BOTTOM SIDE	1	
41	50.401.08.014	DOWEL	2	
42	50.540.09.016	SPRING DOWEL PIN	2	
*43	M-075400003	MAIN BEARING SET	1	(7 PAIRS) STD.
*44	M-075400003	MAIN BEARING SET	1	0.25 mm U/S
*45	M-075400023	MAIN BEARING SET	1	0.50 mm U/S
*46	M-075400033	MAIN BEARING SET	1	0.75 mm U/S

TITLE:- MOUNTING FUEL FILTER SPIN ON TYPE

GROUP:- 6H.112

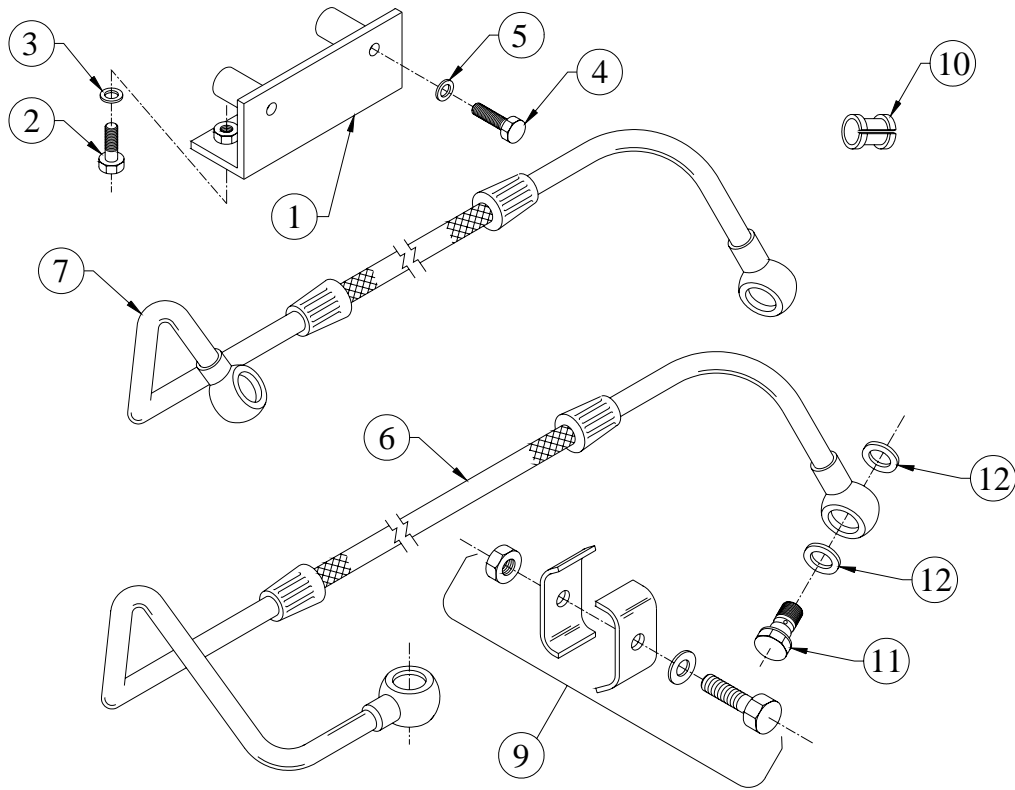

SR.NO.	PART NO.	DESCRIPTION	QTY.	REMARKS
1	3H.191.01.0.00	FUEL FILTER MOUNTING SPIN ON TYPE	1	
2	50.002.10.040	SET BOLT - M10X1.5X40 - 8.8	2	
3	50.506.10.000	PLAIN MACHINED WASHER - M10	2	
4	50.003.12.040	SET SCREW - M12X1.75X40 - 8.8	2	
5	50.506.12.000	PLAIN MACHINED WASHER - M12	2	
6	6H.032.01.0.00	FUEL PIPE (FEED PUMP TO FILTER)	1	
7	6H.112.02.0.00	FULE PIPE FUEL FILTER TO FUEL PUMP	1	
*8	4H.031.20.0.00	CLAMP ASSLY FOR FUEL PIPES	1	CONSIST OF SR. NO. 9, 10
9	4H.031.30.0.00	CLAMP ASSEMBLY (WITHOUT RUBBER SLEEVE)	1	
10	4H.031.07.0.00	RUBBER SLEEVE	2	
11	4H.077.05.0.00	COLLARED BANJO BOLT (M14X1.5 THREAD)	4	
12	4H.077.08.0.00	COMPOSITE WASHER	8	
*13	50.548.12.000	WASHERS	4	NOT ILLUSTRATED

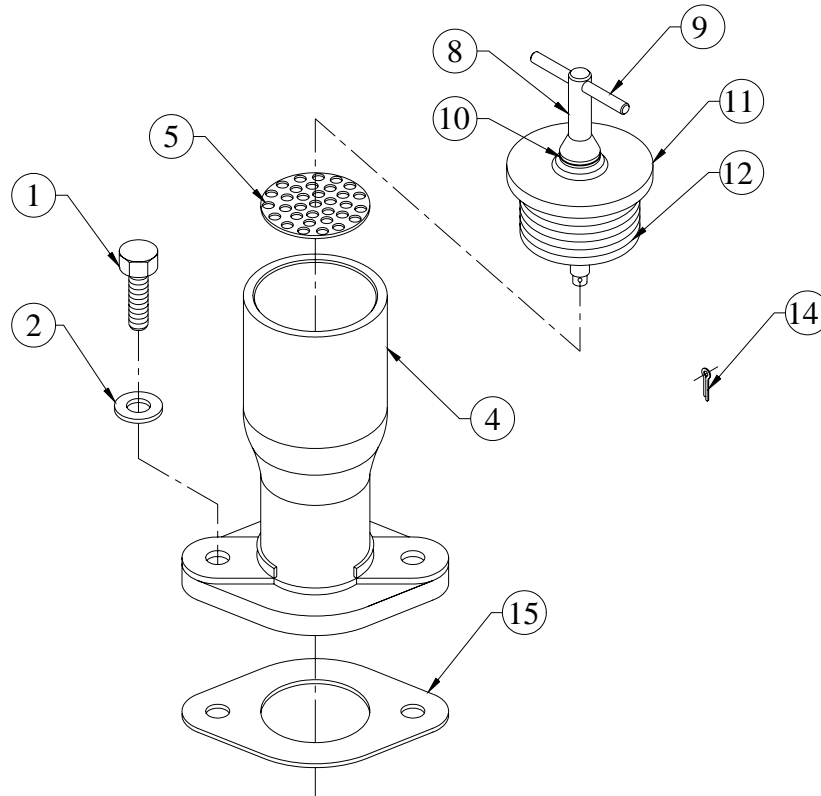
TITLE:- OIL FILLING BODY**GROUP:- 4H.027...EXP**

SR.NO.	PART NO.	DESCRIPTION	QTY.	REMARKS
1	50.003.08.025	SET SCREW - M8X1.25X25 - 8.8	2	
2	50.506.08.000.	PLAIN MACHINED WASHER - M8	2	
*3	4H.027.20.0.00	ASSEMBLY OF OIL FILLING BODY WITH JOINT	1	CONSISTING OF SR. NO.- 4 TO 6, 15
4	4H.027.01.0.00	OIL FILLING BODY	1	
5	34.036.50.0.00	PERFORATED DISC.	1	
*6	34.036.60.0.00	CAP ASSLY	1	CONSISTING OF SR. NO.- 7, 10 TO 14
*7	03.592.10.0.00	SUB-ASSLY.OF CLAMPING SCREW	1	CONSISTING OF SR. NO.- 8 & 9
8	03.592.01.0.00	CLAMPING SCREW FOR CAP	1	
9	34.036.16.0.00	PIN	1	
10	34.036.17.0.00	WASHER	1	
11	34.036.14.0.00	CAP	1	
12	03.592.02.0.00	RUBBER BUSH FOR CAP	1	

TITLE:- OIL SEAL HOUSING

GROUP:- 6H.045...EXP

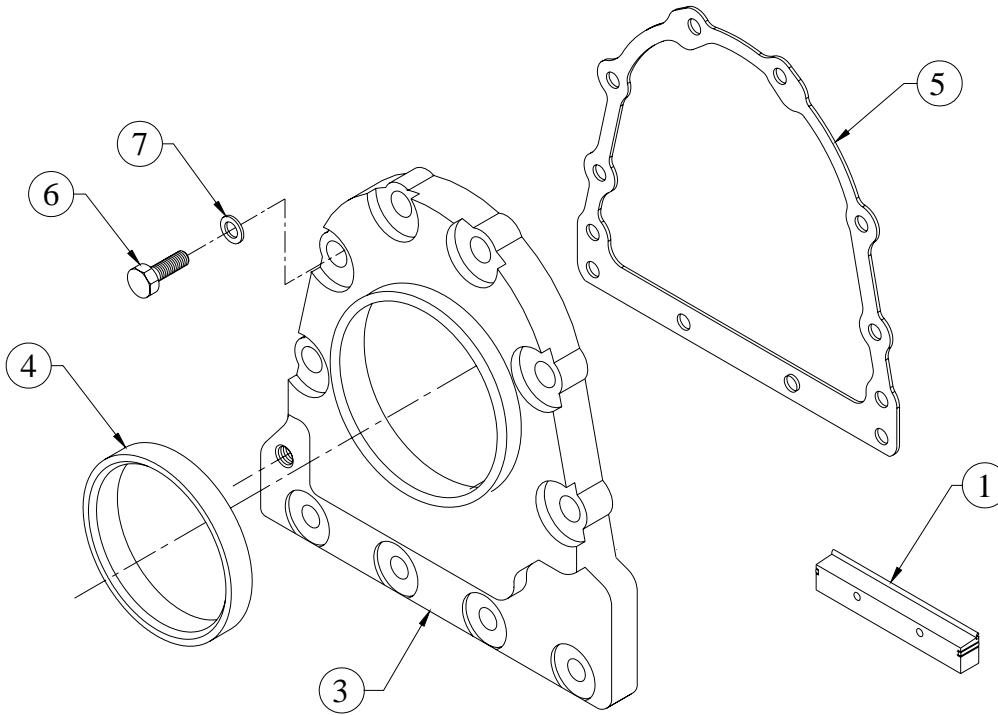

SR.NO.	PART NO.	DESCRIPTION	QTY.	REMARKS
1	2H.039.10.0.00	PLATE WITH RUBBER MOULDING (FOR FWE OIL SEAL HSG.)	1	
*2	6H.045.10.0.00	SUB-ASSLY OF OIL SEAL HOUSING F.W.E.	1	CONSISTING OF SR. NO. 3, 4
3	6H.045.01.0.00	OIL SEAL HOUSING (FWE) FINISH	1	
4	03.007.06.0.00	OIL SEAL (115X140X16) CR MAKE	1	
5	6H.045.11.0.00	JOINT FOR OIL SEAL HOUSING	1	
6	50.003.08.020.	SET SCREW - M8X1.25X20 - 8.8	10	
7	50.506.08.000.	PLAIN MACHINED WASHER - M8	10	

**TITLE :- PISTON & CONNECTING ROD
(TURBO P.G.- 40 DIA. PIN)**

GROUP :- 4H.180

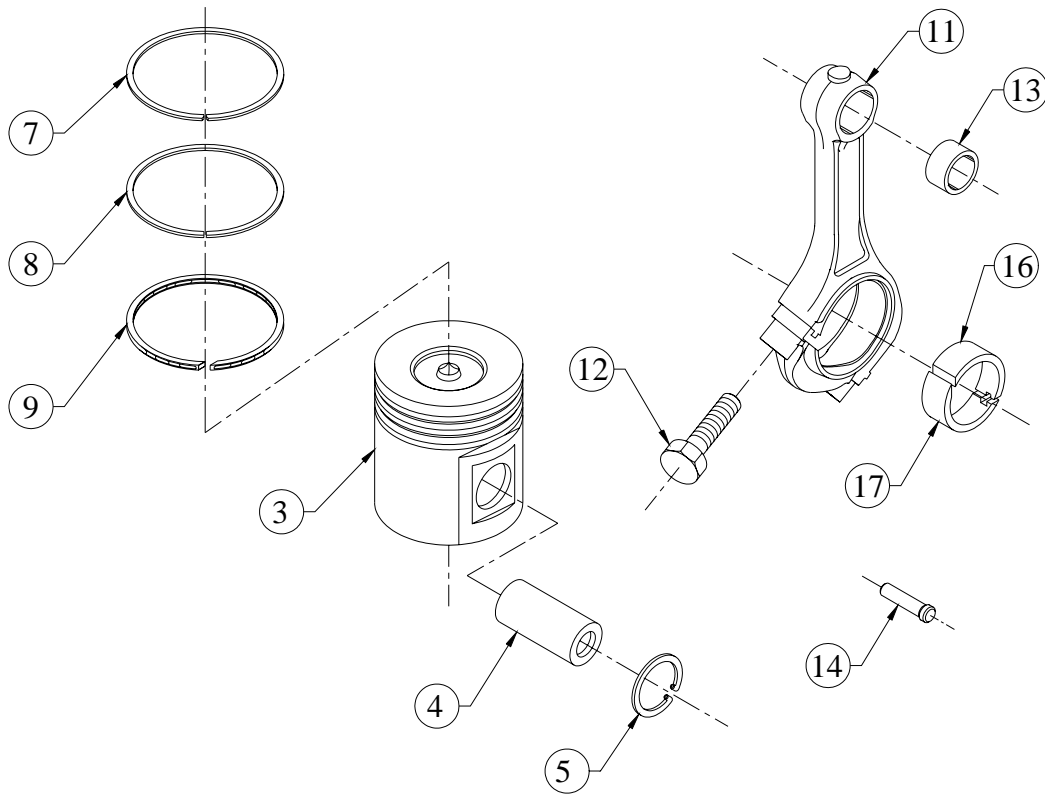

SR.NO.	PART NO.	DESCRIPTION	QTY.	REMARKS
*1	4H.180.40.0.00	PISTON & CON. ROD ASSLY.	1	CONSISTING OF SR. NO.- 2, 10 AND 15
*2	4H.180.10.0.00	PISTON ASSEMBLY COMPLETE	1	CONSISTING OF SR. NO.- 3 TO 6
3	4H.180.01.0.00	PISTON - SUITABLE FOR 40 MM DIA.PIN	1	
4	4H.180.05.0.00	PISTON PIN - 40 MM DIA.	1	
5	50.502.40.000.	CIRCLIP INTERNAL - 40 MM	2	
*6	2H.009.30.0.00	PISTON RING SET (105 DIA.)	1	CONSISTING OF SR. NO.- 7 TO 9
7	2H.009.02.0.00	TOP RING (105 DIA)	1	
8	2H.009.03.0.00	COMPRESSION RING (105 DIA)	1	
9	2H.009.04.0.00	OIL CONTROL RING (105 DIA)	1	
*10	4H.182.10.0.00	CON ROD ASSLY.	1	CONSISTING OF SR. NO.- 11 TO 14

TITLE :- PISTON & CONNECTING ROD
(TURBO P.G.- 40 DIA. PIN)

GROUP :- 4H.180

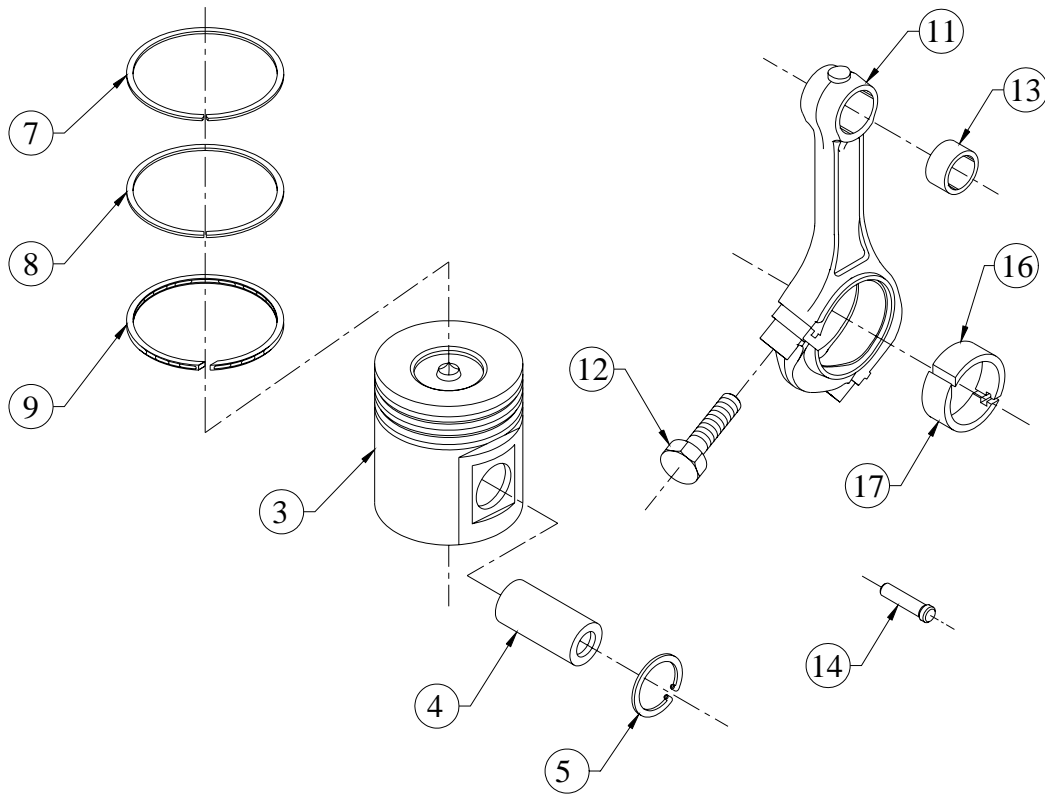

SR.NO.	PART NO.	DESCRIPTION	QTY.	REMARKS
11	4H.182.01.0.00	CON ROD (40 DIA PIN)	1	
12	02.021.08.0.00	CON ROD BOLT (FOR MASS BAL CON ROD)	2	
13	4H.182.02.0.00	SMALL END BUSH (40 DIA)	1	
14	4H.182.03.0.00	LOCATING PIN (FOR CON. ROD)	1	
*15	6H.015.03.0.00	LARGE END BEARING PAIR BEARING PART NO. *B - 075400003)	1	CONSISTOF SR. NO.-16, 17
16	6H.015.04.0.00	CON ROD L.E.BEARING (TOP HALF)	1	
17	6H.015.05.0.00	CON ROD L.E.BEARING (BOTTOM HALF)	1	
*20	B-075400003	L.E. BEARING SET	1	(6 PAIRS) STD.
*21	B-075400013	L.E. BEARING SET	1	0.25 mm U/S
*22	B-075400023	L.E. BEARING SET	1	0.50 mm U/S
*23	B-075400033	L.E. BEARING SET	1	0.75 mm U/S
*24	B-075400043	L.E. BEARING SET	1	1.00 mm U/S
*25	B-075400053	L.E. BEARING SET	1	1.25 mm U/S
*26	B-075400063	L.E. BEARING SET	1	1.50 mm U/S

**TITLE:- RADIATOR FOR 6R1080T/6R1080TA
CANOPIED GENSET W/O STONEGUARD**

GROUP:- 6H.438

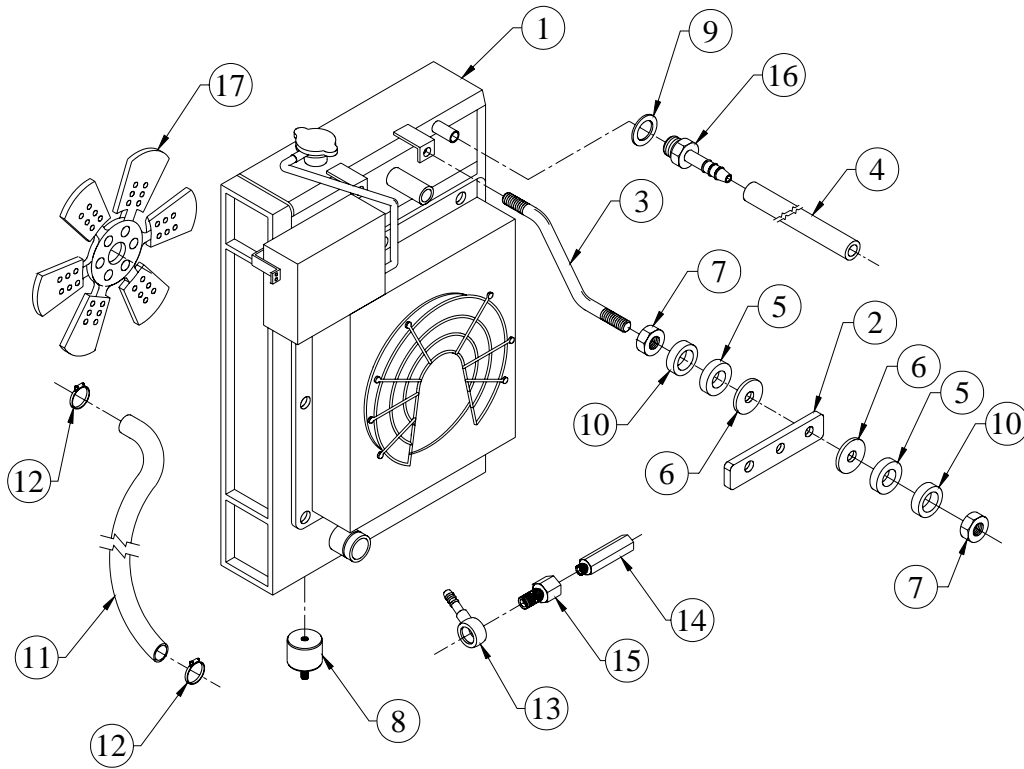

SR.NO.	PART NO.	DESCRIPTION	QTY.	REMARKS
1	6H.438.10.0.00	ASSEMBLY OF RADIATOR FOR 6R1080T/6R1080TA CANOPIED GENSET W/O STONEGUARD	1	
2	6H.019.01.0.00	PLATE FOR STAY	1	
3	6H.019.09.0.00	STAY FOR RADIATOR	2	
4	6H.056.03.0.00	VENT PIPE FOR RADIATOR	1	
5	6H.019.06.0.00	RUBBER BUSH	8	
6	6H.019.08.0.00	SPECIAL WASHER	8	
7	50.006.12.000.	NUT - M12X1.75 - GR.8	4	
8	F6.509.04.0.00	ANTI VIBRATION MOUNTS (POLYBOND: PO 312)	4	
9	50.508.12.000.	COPPER WASHER (14X20)	2	
10	6H.019.07.0.00	BUSH	4	
11	6H.019.12.0.00	HOSE (FOR WATER PIPE)	1	
12	50.519.07.000.	WORM DRIVE HOSE CLIP (35 MM)	2	
13	06.610.10.0.00	SUB ASSLY OF HOSE TAIL (M14 BANJO)	1	
14	4H.225.13.0.00	SPACER FOR VENT CONNECTION	1	

TITLE: -ROCKER COVER (FOR CCV)

GROUP: -6H.442...EXP

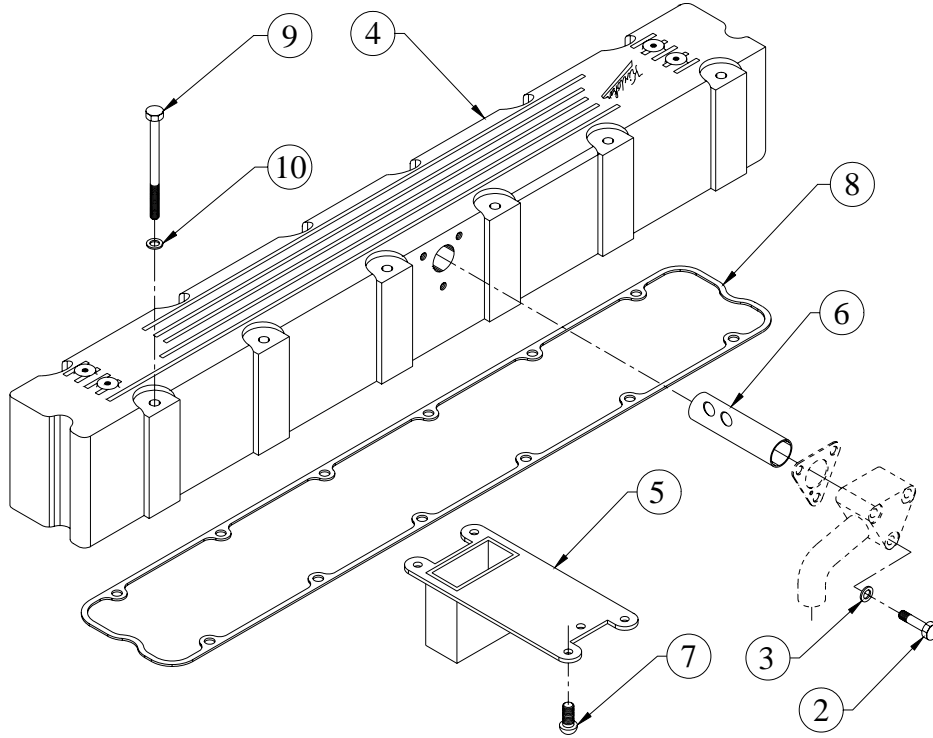

SR.NO.	PART NO.	DESCRIPTION	QTY.	REMARKS
*1	6H.442.40.0.00	SUBSSEMBLY OF ROCKER COVER	1	CONSISTING OF SR. NO.- 2 TO 7
2	50.002.08.055	SET BOLT - M8X1.25X55 - 8.8	3	
3	50.506.08.000	PLAIN MACHINED WASHER - M8	3	
4	6H.442.01.0.PR	ROCKER COVER (FOR CCV VALVE)	1	
5	6H.013.05.0.00	DEFLECTOR PLATE	2	
6	6H.013.04.0.00	BREATHER TUBE	1	
7	10.046.02.0.00	P K DRIVE SCREW 1/8"X3/8" (RIVET)	8	
8	6H.013.11.0.00	JOINT FOR ROCKER COVER	1	
9	50.002.08.110	SET BOLT - M8X1.25X110 - 8.8	12	
10	50.506.08.000	PLAIN MACHINED WASHER - M8	12	

TITLE :- SUCTION TUBE

GROUP :- 6H.006

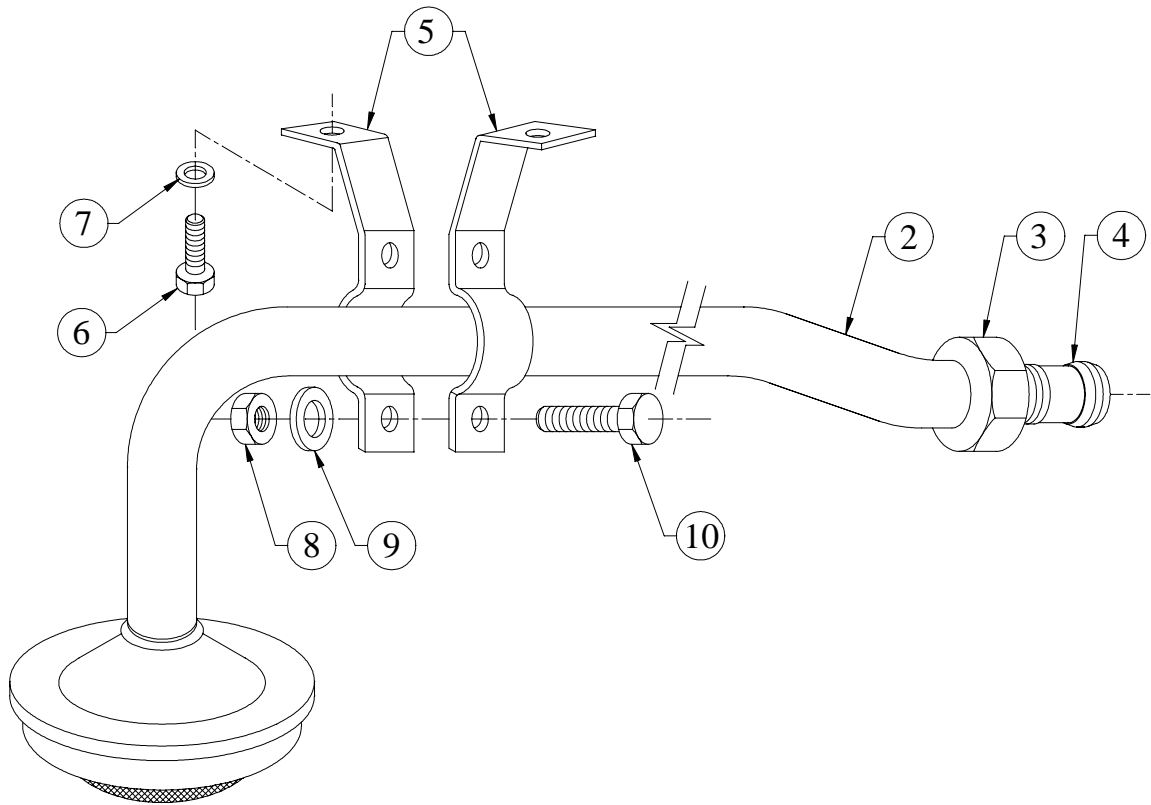

SR.NO.	PART NO.	DESCRIPTION	QTY.	REMARKS
*1	6H.006.10.0.00	SUCTION TUBE ASSEMBLY.	1	CONSISRING OF SR. NO. 2 TO 8
2	6H.006.20.0.00	SUCTION TUBE SUB.ASSEMBLY.	1	
3	06.008.02.0.00	UNION NUT	1	
4	06.008.03.0.00	DOUBLE CONE RING	1	
5	06.008.04.0.00	CLAMPING STRAP	2	
6	50.003.06.012.	SET SCREW - M6X1X12 - 8.8	2	
7	50.506.06.000.	PLAIN MACHINED WASHER - M6	4	
8	50.006.06.000.	NUT - M6X1 - GR.8	2	
9	50.003.08.016.	SET SCREW - M8X1.25X16 - 8.8	2	
10	50.506.08.000.	PLAIN MACHINED WASHER - M8	2	

TITLE:- THERMOSTAT AND HOUSING ASSEMBLY (USA)

GROUP:- 4H.096...EXP

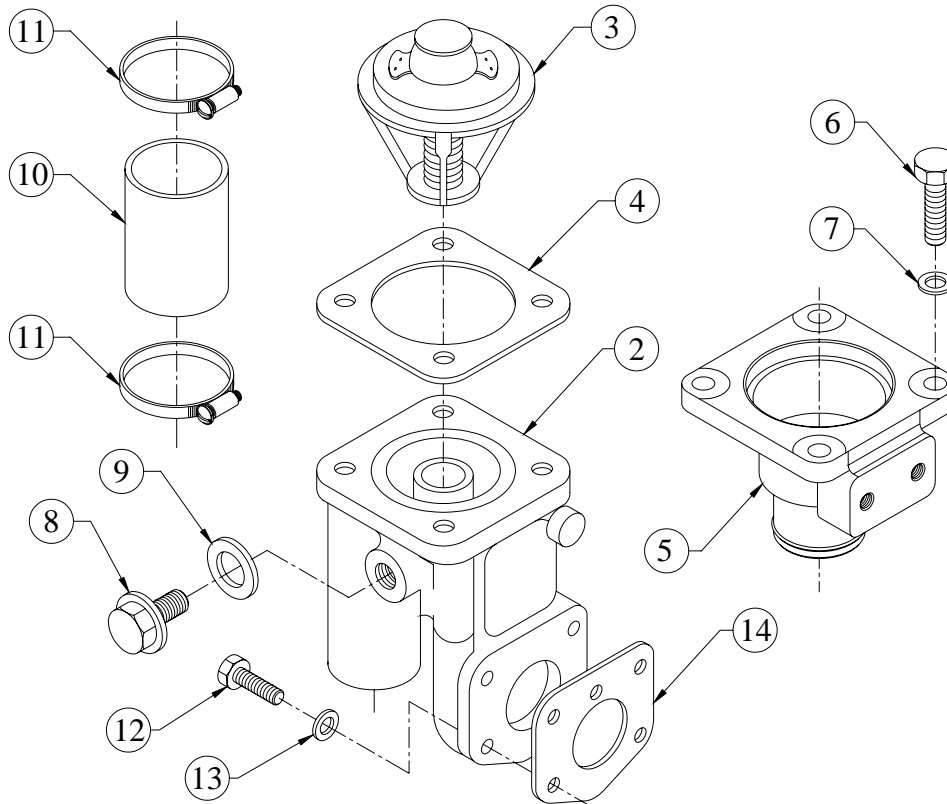

SR.NO.	PART NO.	DESCRIPTION	QTY.	REMARKS
*1	4H.096.20.0.00	THERMOSTAT AND HOUSING ASSEMBLY (NON ASBESTOS JOINT)	1	CONSISTING OF SR. NO. 3 TO 7 AND 10 TO 13
2	4H.053.01.0.00	THERMOSTAT HOUSING	1	
3	39.040.09.0.00	THERMOSTAT ELEMENT (74 DEG) - WTIL NO.DEV358	1	
4	4H.053.12.0.00	JOINT FOR THERMOSTAT COVER	1	
5	4H.096.03.0.00	THERMOSTAT COVER	1	
6	50.003.08.025	SET SCREW - M8X1.25X25 - 8.8	4	
7	50.506.08.0.00	PLAIN MACHINED WASHER - M8	4	
8	50.602.14.0.00	PLUG (M14X1.5)	1	
9	50.565.14.0.00	INTERNAL RUBBER LIP SEALING WASHER	1	
10	4H.023.02.0.00	BYPASS HOSE	1	
11	4H.405.07.0.00	STAINLESS STEEL HOSE CLIP S/F 35 TO 41 MM HOSE O.D (TO REPLACE 50519/08)	2	
12	50.003.08.025	SET SCREW - M8X1.25X25 - 8.8	4	

TITLE:- TURBO LUB OIL PUMP (K26)

GROUP:- 6H.034...EXP

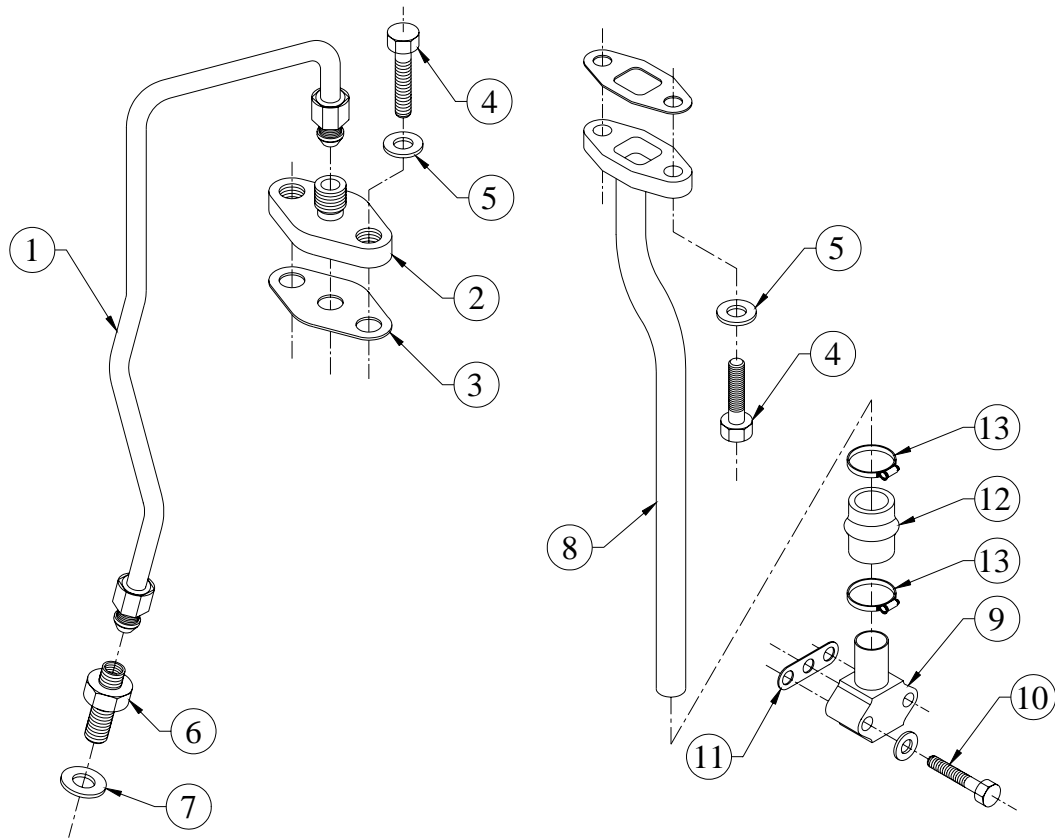

SR.NO.	PART NO.	DESCRIPTION	QTY.	REMARKS
1	6H.034.04.0.00	L.O.INLET PIPE (FOR K24 TURBO)	1	
2	4H.132.02.0.00	ADAPTOR (TURBOCHARGER SIDE)	1	
3	4H.132.27.0.00	JOINT FOR ADAPTOR (TURBO SIDE)	1	
4	50.003.08.025	SET SCREW - M8X1.25X25 - 8.8	4	
5	50.506.08.000	PLAIN MACHINED WASHER - M8	6	
6	6H.034.03.0.00	ADAPTOR FOR OIL PIPE	1	
7	50.508.14.000	COPPER WASHER (16X22)	2	
8	6H.034.05.0.00	L.O. DRAIN PIPE (FOR K26 TURBO)	1	
9	4H.132.13.0.00	ADAPTOR ASSEMBLY FOR TURBO DRAIN (CRANKCASE SIDE)	1	
10	50.002.08.045	SET BOLT - M8X1.25X45 - 8.8	2	
11	4H.132.28.0.00	JOINT FOR ADAPTOR (CRANKCASE SIDE)	1	
12	4H.366.07.0.00	HOSE (FOR TURBO DRAIN PIPE)	1	
13	50.519.07.000	WORM DRIVE HOSE CLIP (35 MM)	2	

TITLE: - VALVE ROCKER ASSEMBLY

GROUP: - 6H.012

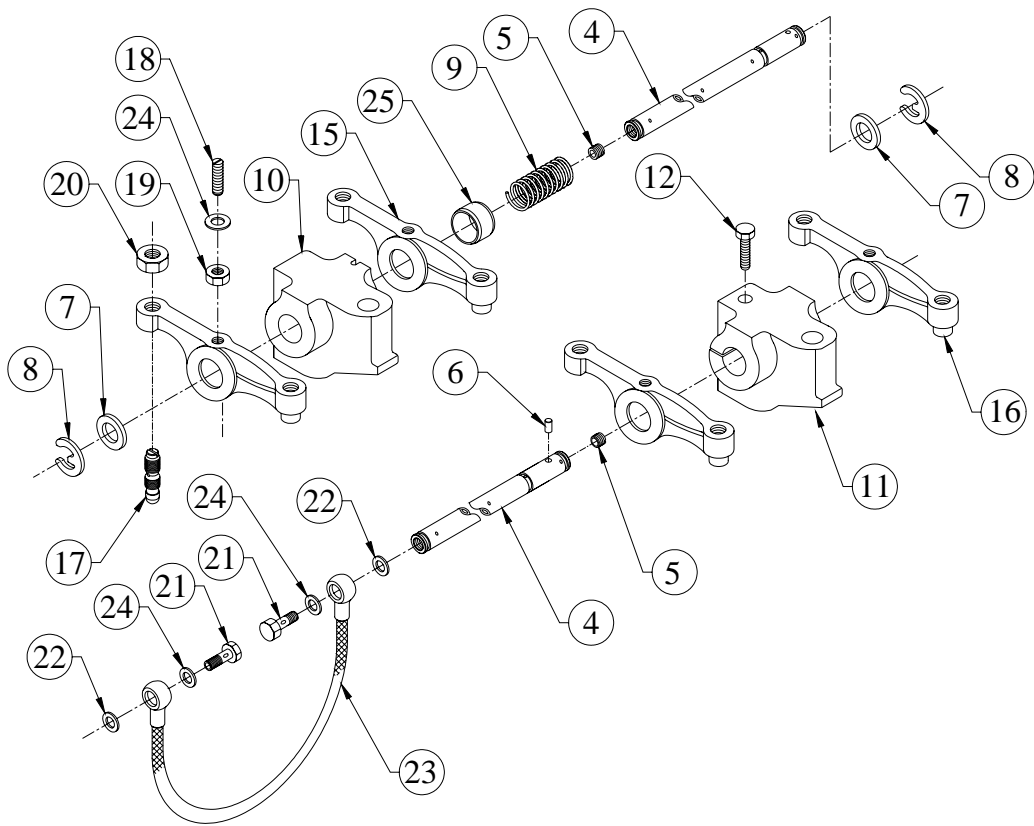

SR.NO.	PART NO.	DESCRIPTION	QTY.	REMARKS
*1	6H.012.10.0.00	ROCKER SHAFT ASSLY. (COMPLETE)	1	CONSISTING OF SR. NO. 2, 21 TO 23
*2	6H.012.20.0.00	ROCKER SHAFT SUB ASSLY.	2	CONSISTING OF SR. NO. 3 & 7 TO 13 & 24
*3	3H.010.20.0.00	VALVE ROCKER SHAFT SUB ASSLY.	1	CONSISTING OF SR. NO. 4 TO 6
4	3H.010.01.0.00	ROCKER SHAFT	1	
5	50.022.12.010.	SOCKET HEAD GRUB SCREW - M12X10	2	
6	4H.008.04.0.00	GROOVED SOCKET PIN	1	
7	2H.022.04.0.00	WASHER (FOR ROCKER ARM)	2	
8	50.513.15.000.	E TYPE CIRCLIP-EXTERNAL (15 DIA.)	2	
9	2H.022.03.0.00	SPRING FOR ROCKER SHAFT.	2	
10	2H.022.01.0.00	ROCKER SUPPORT (FINISH)(FWE)	1	
11	2H.022.02.0.00	ROCKER SUPPORT (FINISH)	2	
12	50.003.08.030.	SET SCREW - M8X1.25X30 - 8.8	2	

TITLE: - VALVE ROCKER ASSEMBLY

GROUP: - 6H.012

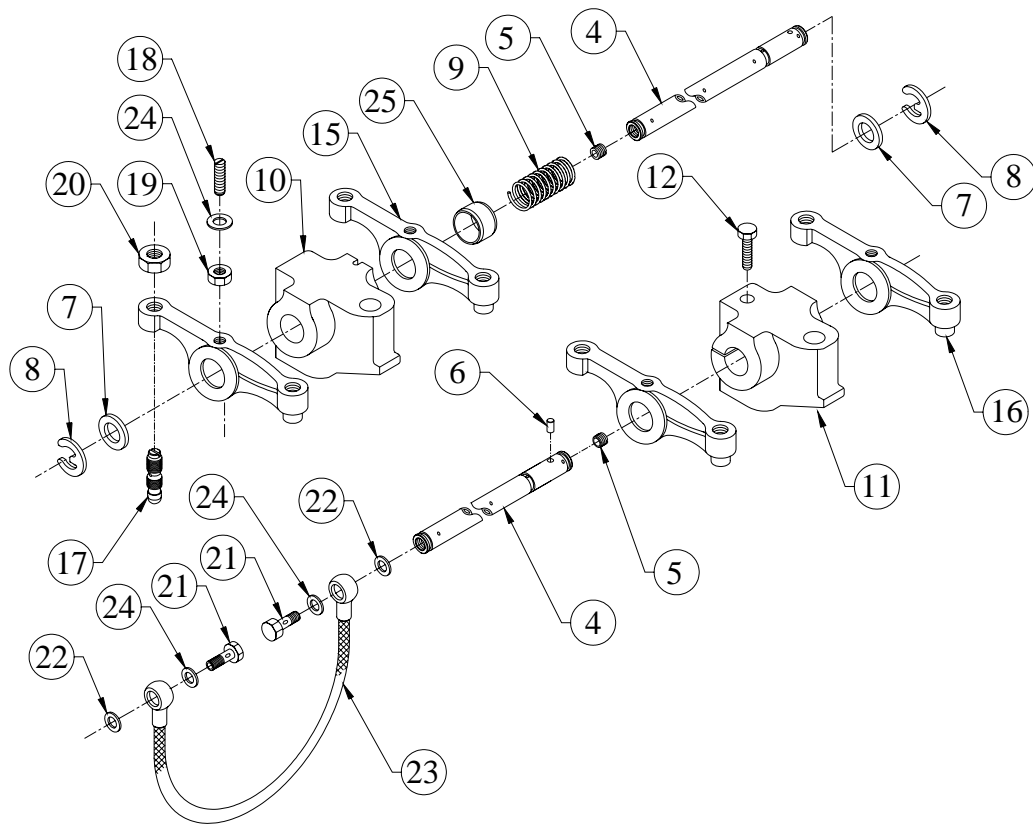

SR.NO.	PART NO.	DESCRIPTION	QTY.	REMARKS
*13	02.024.20.0.00	VALVE ROCKER ASSLY	6	CONSISTING OF SR. NO. 14 & 16 TO 20 & 25
*14	02.024.23.0.00	ROCKER ARM SUB ASSEMBLY (WITH VR BUSH)	1	CONSISTING OF SR. NO.15
15	02.024.11.0.00	ROCKER ARM	1	
16	02.024.15.0.00	V.R.TOES	1	
17	02.024.13.0.00	ROCKER-ARM ADJ. SCREW	1	
18	02.024.14.0.00	OIL METERING SCREW	1	
19	50.006.06.000.	NUT - M6X1 - GR.8	1	
20	60.007.03.0.00	NUT	1	
21	6H.012.02.0.00	BANJO BOLT	2	
22	50.565.12.000.	INTERNAL RUBBER LIP SEALING WASHER -M12- FOR FUEL LINES	4	
23	6H.012.03.0.00	ASSEMBLY OF ADAPTOR & PIPE	1	
24	F6.007.13.0.00	WASHER	10	
25	02.024.12.0.00	V.R. BUSH	2	

TITLE :- WATER IN & OUT CONNECTION

GROUP :- 6H.036

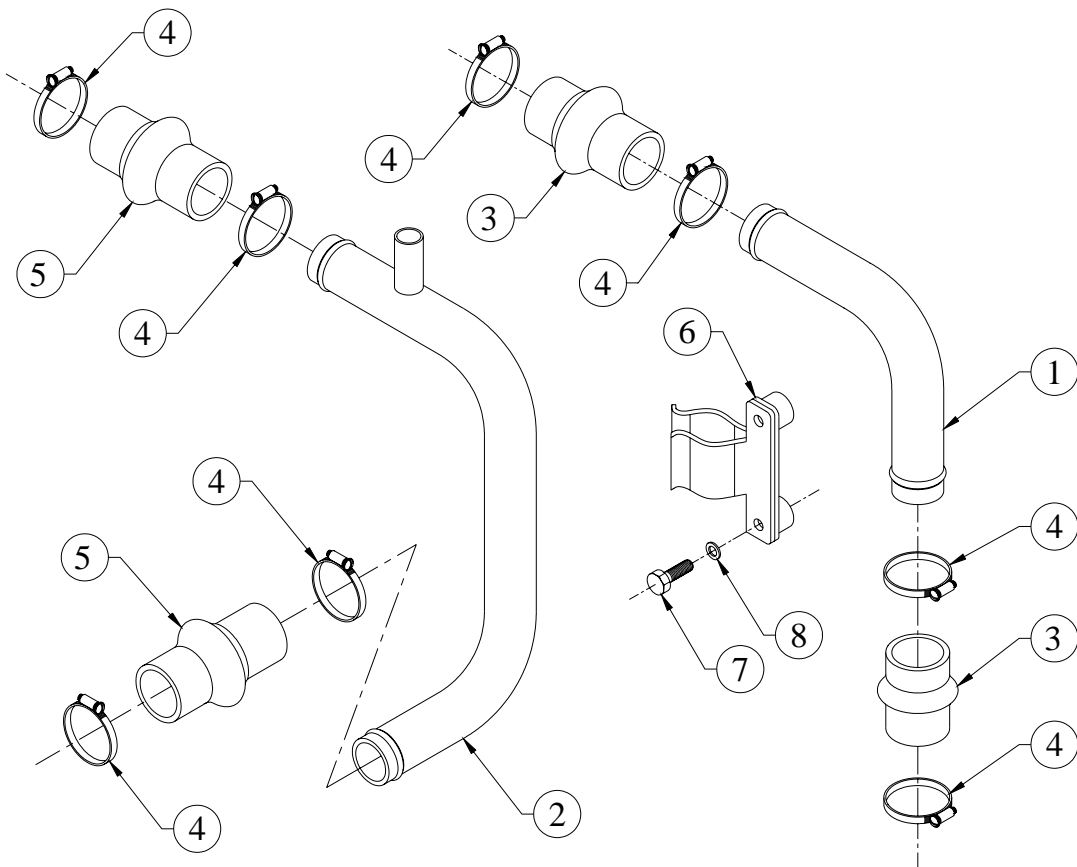

SR.NO.	PART NO.	DESCRIPTION	QTY.	REMARKS
1	6H.036.03.0.00	PIPE (THERMOSTAT TO RADIATOR)	1	
2	6H.036.04.0.00	PIPE (RADIATOR TO PUMP INLET)	1	
3	4H.073.01.0.00	HOSE THERMOSTAT TO RADIATOR(45X45X110L)	2	
4	50.519.11.000.	WORM DRIVE HOSE CLIP (61 MM)	8	
5	4H.073.02.0.00	HOSE WATER PUMP TO RADIATOR(45X45X80L)	2	
6	4H.073.10.0.00	CLAMP ASSLY FOR PIPE	1	
7	50.002.08.075.	SET BOLT - M8X1.25X75 - 8.8	2	
8	50.506.08.000.	PLAIN MACHINED WASHER - M8	2	

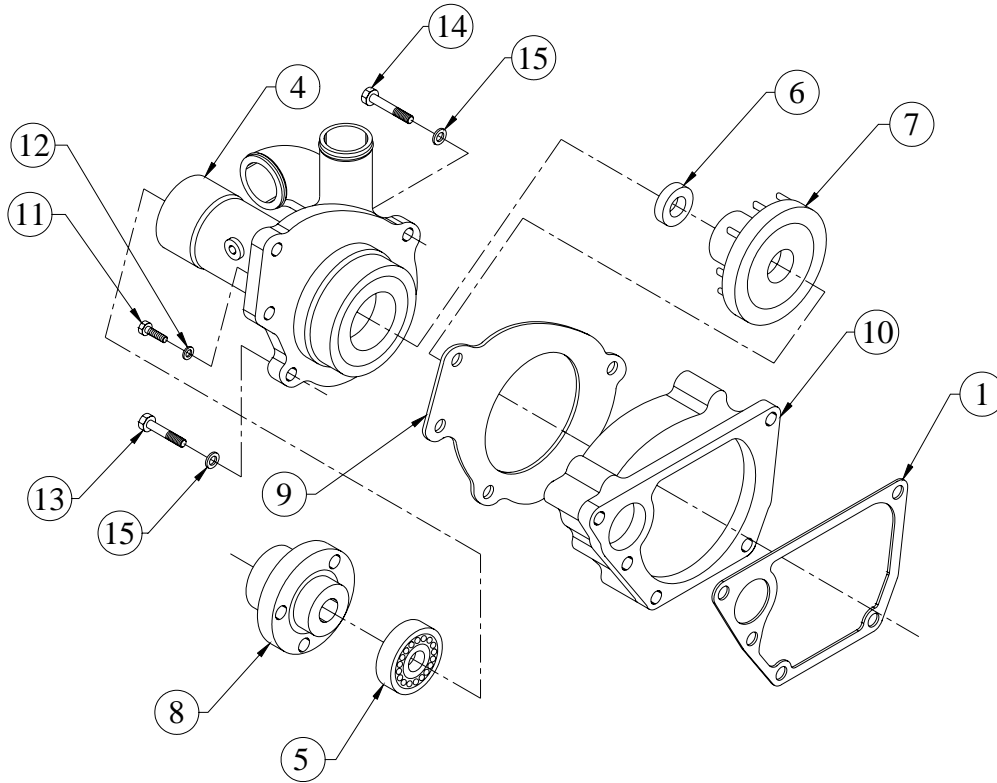
TITLE: -WATER PUMP**GROUP: -4H.052...EXP**

SR.NO.	PART NO.	DESCRIPTION	QTY.	REMARKS
1	4H.052.12.0.00	JOINT FOR DELIVERY VOLUTE	1	
*2	4H.052.95.0.00	WATER PUMP ASSEMBLY (HIGHER BEARING SIZE)	1	CONSISTING OF SR. NO.- 3, 10 TO 12
*3	4H.052.70.0.00	SUB ASSEMBLY OF DILEVERY VOLUTE	1	CONSISTING OF SR. NO.- 4 TO 9
4	4H.052.05.0.00	BEARING HOUSING (FOR 42 DIA SPINDLE BEARING)	1	
5	4H.052.06.0.00	SPINDLE BEARING (42 DIA)	1	
6	4H.052.07.0.00	UNITISED SEAL (KACO)	1	
7	4H.021.04.0.00	IMPELLER (95 DIA)	1	
8	4H.021.07.0.00	HUB FOR PUMP PULLEY	1	
9	4H.052.11.0.00	JOINT FOR BEARING HOUSING (282.5 CRS)	1	
10	4H.052.02.0.00	DELIVERY VOLUTE (282.5 CRS)	1	
11	50.003.08.025	SET SCREW - M8X1.25X25 - 8.8	3	
12	10.020.03.0.00	HARD WASHER (F)	3	
13	50.002.10.060	SET BOLT - M10X1.5X60 - 8.8	3	

**TITLE: -SET OF JOINTS, WASHERS,
'O' RINGS & HOSES (6H.2465)**

GROUP: -

SR.NO.	PART NO.	DESCRIPTION	QTY.	REMARKS
*1	6H.061.48.0.00	SET OF JOINTS	1	CONSISTING OF SR. NO.- 2 TO 28
*2	06.015.02.0.00	JOINT FOR LUB OIL SUMP	1	
*3	2H.013.11.0.00	JOINT FOR DELIVERY BODY	1	
*4	2H.017.11.0.00	JOINT FOR COVER FOR FUEL PUMP GEAR	1	
*5	2H.037.11.0.00	JOINT FOR FRONT COVER	1	
*6	34.016.11.0.00	JOINT	1	
*7	3H.015.11.0.00	JOINT FOR AIR INLET MANIFOLD	2	
*8	4H.027.11.0.00	JOINT FOR OIL FILLING BODY	1	
*9	4H.035.06.0.00	GASKET (FOR EXHAUST MANIFOLD)	6	
*10	4H.052.11.0.00	JOINT FOR BEARING HOUSING (282.5 CRS)	1	
*11	4H.052.12.0.00	JOINT FOR DELIVERY VOLUTE	1	
*12	4H.053.11.0.00	JOINT FOR THERMOSTAT HOUSING	1	
*13	4H.053.12.0.00	JOINT FOR THERMOSTAT COVER	1	

**TITLE: -SET OF JOINTS, WASHERS,
'O' RINGS & HOSES (6H.2465)**

GROUP: -

SR.NO.	PART NO.	DESCRIPTION	QTY.	REMARKS
*14	4H.132.27.0.00	JOINT FOR ADAPTOR (TURBO SIDE)	1	
*15	4H.132.28.0.00	JOINT FOR ADAPTOR (CRANKCASE SIDE)	1	
*16	6H.007.06.0.00	GASKET (FOR CYL.HEAD)-1.22 MM THK.	1	
*17	6H.013.11.0.00	JOINT FOR ROCKER COVER	1	
*18	6H.014.11.0.00	JOINT FOR HEADER	1	
*19	6H.020.11.0.00	JOINT BETWEEN CRANKCASE AND GEAR COVER	1	
*20	6H.021.11.0.00	JOINT FOR CENTRIFUGAL FILTER ADAPTOR	1	
*21	6H.024.02.0.00	JOINT (ADAPTOR FOR BREATHER)	2	
*22	6H.026.02.0.00	SS JOINT FOR TURBO OUTLET	1	
*23	6H.029.01.0.00	GASKET (FOR TURBOCHARGER)	1	
*24	6H.045.11.0.00	JOINT FOR OIL SEAL HOUSING	1	
*25	6H.058.02.0.00	JOINT FOR AIR PIPE	1	
*26	F6.024.75.0.00	JOINT FOR GLACIER FILTER	1	
*27	F6.036.07.0.00	JOINT FOR LUB OIL COOLER	1	

**TITLE: -SET OF JOINTS, WASHERS,
'O' RINGS & HOSES (6H.2465)**

GROUP: -

SR.NO.	PART NO.	DESCRIPTION	QTY.	REMARKS
*28	F6.503.02.0.00	S.S.JOINT (4")	2	
*29	6H.061.50.0.00	SET OF WASHERS	1	CONSISTING OF SR. NO.- 30 TO 43
*30	50.508.05.000	COPPER WASHER (8X12)	12	
*31	50.508.07.000	COPPER WASHER (10X14)	4	
*32	50.508.10.000	COPPER WASHER (12X18)	1	
*33	50.508.12.000	COPPER WASHER (14X20)	2	
*34	50.508.14.000	COPPER WASHER (16X22)	4	
*35	50.508.15.000	COPPER WASHER (17X23)	1	
*36	50.508.16.000	COPPER WASHER (18X22)	2	
*37	50.508.18.000	COPPER WASHER (20X24)	2	
*38	50.508.23.000	COPPER WASHER (22X27)	1	
*39	50.508.27.000	COPPER WASHER (24X29)	1	
*40	50.508.29.000	COPPER WASHER (26X32)	5	
*41	50.565.10.000	INTERNAL RUBBER LIP SEALING WASHER -M10- FOR FUEL LINES	1	
*42	50.565.12.000	INTERNAL RUBBER LIP SEALING WASHER -M12- FOR FUEL LINES	4	

**TITLE: -SET OF JOINTS, WASHERS,
'O' RINGS & HOSES (6H.2465)**

GROUP: -

SR.NO.	PART NO.	DESCRIPTION	QTY.	REMARKS
*43	50.565.14.000	INTERNAL RUBBER LIP SEALING WASHER -M14- FOR FUEL LINES	13	
*44	6H.464.51.0.00	SET OF 'O' RINGS	1	CONSISTING OF SR. NO.- 45 TO 50
*45	03.010.11.0.00	O RING – L.O.PUMP (1.57X65, 21508)	2	
*46	03.036.01.0.00	O RING - DIPSTICK (2X5, 21515 OR 21511)	3	
*47	2H.008.07.0.00	O RING (FOR CYL.LINER)	3	
*48	2H.014.02.0.00	O RING (FOR DELIVERY TUBE)	2	
*49	3H.009.11.0.00	O RING FOR NOZZLE	1	
*50	3H.132.03.0.00	SEALING RING (FUEL FILTER)	2	
*51	6H.464.52.0.00	SET OF HOSES	1	CONSISTING OF SR. NO.- 52 TO 60
*52	02.601.04.0.00	HOSE FOR INLET PIPE	4	
*53	4H.006.01.0.00	L.O.SUPPLY HOSE (FIP)	1	
*54	4H.023.02.0.00	BYPASS HOSE	1	
*55	4H.073.01.0.00	HOSE THERMOSTAT TO RADIATOR (45X45X110L)	2	

